

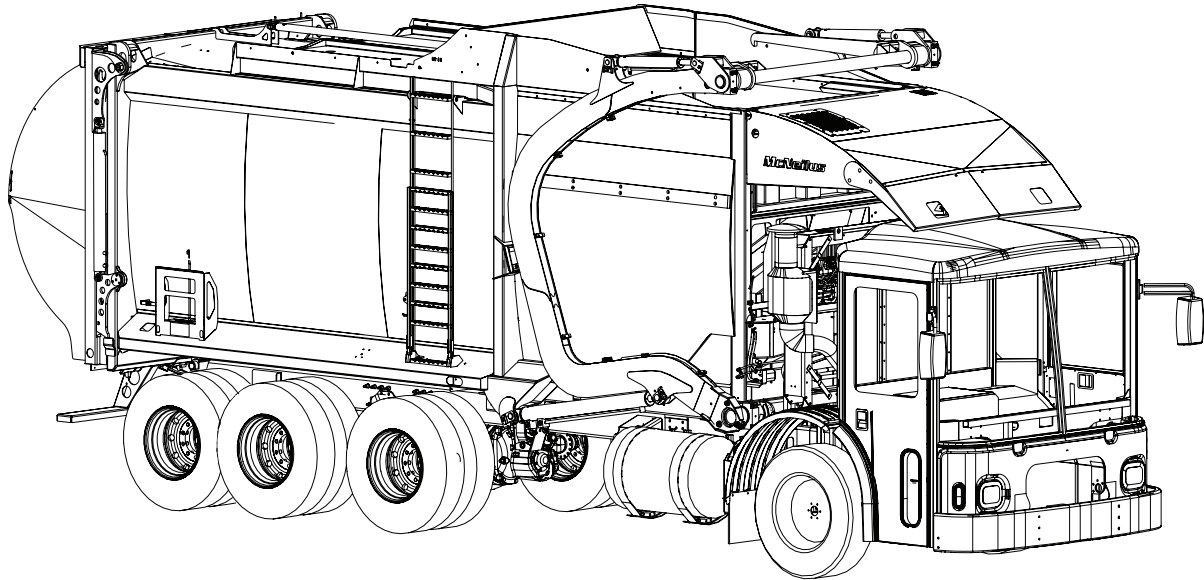

An Oshkosh Corporation Company

OPERATOR'S MANUAL

Contender Front Loader



Disclaimer:

This manual must not be used to repair your vehicle. Repair information is available by calling McNeilus Customer Service at (888) 686-7278.

The information in this Operator's Manual will be your guide to operation and operator maintenance for this equipment.

All information, illustrations, and specifications in this manual are based on the information available at the time this manual was published. The illustrations used in this manual are intended as representative reference views only. Because of our continuous product improvement policy, we may modify information, illustrations, and/or specifications to explain and/or exemplify a product, service, or maintenance improvement. We reserve the right to make any change at any time without notice. Go to www.streetsmartparts.com for current information.

No part of this publication may be reproduced by any means - graphic, electronic, or mechanical, including photocopying, recording, taping, or information storage and retrieval systems for any use or purpose - without the written permission of McNeilus Truck and Manufacturing, Inc.

For assistance in ordering the Waste Collection Vehicle Safety Guide, contact:
National Waste and Recycling Association
1550 Crystal Drive • Suite 804
Arlington, VA 22202
Telephone: 800-424-2869 • Fax: 202-966-4824

For assistance in ordering OSHA Publications, contact:
U.S. Department of Labor/OSHA
OSHA Publications
P.O. Box 37535
Washington, D.C. 20210
Telephone: 202-693-1888 • Fax: 202-693-2498

1.0 Identification Plate

A McNeilus Truck and Manufacturing, Inc. Identification plate (Figure 1) is located on the left front side of the body. The identification plate contains the Model Number and Serial Number of your refuse system.

To serve you better, please fill out the following information and have it ready when calling McNeilus Truck and Manufacturing, Inc. for parts or product information:

Date of Purchase: _____

McNeilus Branch: _____

Model Number of Refuse Vehicle: _____

Serial Number of Refuse Vehicle: _____

VIN* _____

*Refer to chassis manufacturer literature for location.

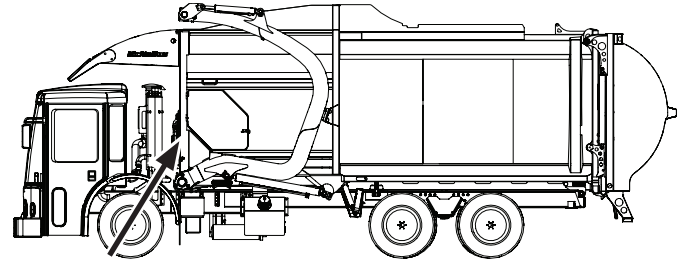

Figure 1

2.0 Complete Vehicle Document Decal

The Complete Vehicle Document Decal (Figure 2) documents the axle load and tire ratings as the vehicle left the McNeilus production line. This decal is located inside the cab and may be placed on the driver's door, doorjamb, or the seat riser.

This decal includes information such as the Maximum rated weight per axle (Item 2), Gross Vehicle Weight (Item 3), Chassis manufacturer (Item 4), Chassis build date (Item 5), Vehicle (chassis) ID number (Item 6), Tire and rim size and tire pressure specifications (Item 7), and the Refuse vehicle system build date (Item 8).

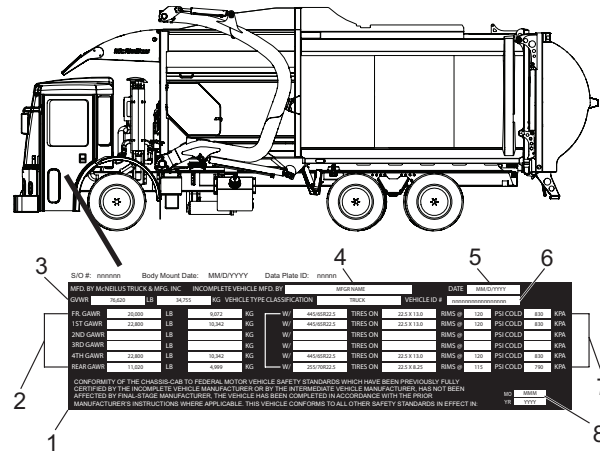

Figure 2

3.0 Purpose of Manual

This Operator Manual provides operation and operator maintenance instructions for the Contender Front Loader refuse collection system manufactured by McNeilus Truck and Manufacturing, Inc.

The information in this operator manual will be your guide to operation and operator maintenance for this equipment.

Keep this manual with the vehicle at all times.

WARNING

The operator of this vehicle must be properly licensed and trained to operate this vehicle.

If you do not have the proper training and licensing to operate this vehicle, you are putting yourself and others at risk of serious injury or death.

If you are uncertain how to operate this Packer, inform your supervisor or contact McNeilus Truck and Manufacturing, Inc. at 888-686-7278.

NOTE

This manual is limited to the operation and light maintenance of the refuse collection system only.

This manual does not include the operation or maintenance of the chassis vehicle upon which the refuse collection system is mounted.

4.0 Scope

This manual provides information for use by the equipment operator under the following headings:

1. **Safety.** Includes important safety information.
2. **General.** Includes equipment identification.
3. **Operation.** Includes control functionality and normal equipment operation.
4. **Preventive Maintenance.** Includes basic preventive maintenance information for the operator.
5. **Troubleshooting.** Includes basic troubleshooting information for the operator.

To order a replacement manual or safety signs, call McNeilus Parts and Service at 888-686-7278.

5.0 Parts and Service

Contact your McNeilus Parts and Service branch locations to order parts, receive service information, or for other assistance. Contact by phone or visit www.streetsmartparts.com. We have factory owned parts and service centers near you.

Phone Number

888-686-7278

State	City	State	City
CA	Colton	OH	Cincinnati
CT	East Granby	OH	Columbus
FL	Tampa	PA	Morgantown
GA	Villa Rica	TX	Houston
IL	Sugar Grove	TX	Hutchins
IN	Fort Wayne	UT	West Valley City
MN	Dodge Center	WI	Oshkosh
NY	Bronx		

Canada

Ontario and Western Provinces	800-265-1089
Quebec and Maritime Provinces	800-996-4937

6.0 Corporate Headquarters

Contact McNeilus Truck and Manufacturing, Inc. directly at our corporate headquarters at the following address, phone number, and website.

McNeilus Truck and Manufacturing, Inc.

524 County Road 34 East

Dodge Center, MN 55927

Telephone: 507-374-6321

Corporate Website: www.mcneiluscompanies.com

Parts and Service Website: www.streetsmartparts.com

SAFETY

1.0 IMPORTANT SAFETY INFORMATION1

 1.1 Battery Disconnect Switch2

 1.1.1 Battery Cable Disconnect2

 1.2 Safety Equipment3

 1.3 Reporting Safety Defects3

2.0 SAFETY NOTICES4

3.0 PRODUCT SAFETY INFORMATION5

 3.1 Safety5

 3.2 Cab Operation6

 3.3 Maintenance10

 3.4 Outside Operation13

 3.5 Hydraulics18

 3.6 Electrical21

4.0 SAFETY SIGNS22

 4.1 Safety Sign Location24

GENERAL INFORMATION

1.0 EXTERIOR SYSTEMS ARRANGEMENT27

 1.1 Street Side View27

 1.2 Curb Side View28

 1.3 S-Type Container Specifications29

OPERATION

1.0 OPERATING PROCEDURES31

 1.1 Start-Up Procedure.....31

 1.2 Warm-Up Procedure.....32

 1.3 Traveling Procedure - Standard.....33

 1.4 Traveling Procedure - Residential34

 1.5 Preparation Before Starting Route35

 1.6 Neutral Interlock Test Procedure for Optional Neutral Interlock35

 1.7 Refuse Loading Procedure.....36

 1.8 Refuse Empty Procedure38

 1.9 End of Day Checks.....39

2.0 CONTROL BOX AND INSTRUMENTS39

 2.1 Cab Controls.....40

 2.2 Control Box.....41

 2.2.1 Refuse Vehicle Button Functions.....42

 2.2.2 LED Indicator Light Functions45

 2.2.3 Fuse Block.....48

 2.3 Arm and Fork Controls.....50

 2.3.1 Street Side/Curb Side Switch50

 2.3.2 Single Lever Joystick Control51

 2.3.3 Single Lever Joystick Control (Optional)52

2.3.4	Dual Lever Controls (Optional)	53
2.3.5	Auto Dump Single Lever	54
2.4	Outside Control Box (Optional).....	55
3.0	CONTROL FUNCTIONS	56
3.1	E-STOP (Emergency Stop) Function	56
3.1.1	In-Cab Control Panel E-STOP Button	56
3.1.2	Outside Control Box E-STOP Button.....	56
3.2	Pack/Eject Functions	58
3.2.1	Automatic Cycling of Pack/Eject	58
3.2.2	Manual Cycling of Pack/Eject.....	59
3.2.3	Manual Cycling with Tailgate Open	60
3.3	Arm Functions.....	61
3.4	Fork Functions.....	62
3.5	Auto Dump Functions (Optional)	63
3.6	Tailgate Functions.....	64
3.6.1	Open Tailgate	65
3.6.2	Close Tailgate	65
3.7	Top Door Functions	66
3.7.1	Open Top Door	66
3.7.2	Close Top Door.....	66

4.0	OPTIONAL EQUIPMENT	67
4.1	Residential Attachments	67
4.1.1	Installing a Carry Can	68
4.2	Pusher Axle or Tag Axle	69
4.2.1	Lowering the Pusher or Tag Axle	70
4.2.2	Raising the Pusher Axle or Tag Axle	70
4.3	Fall Protection Equipment	70
4.3.1	Fall Protection Roof Anchors	70
4.3.2	Fall Protection Systems	71
4.3.3	Working on the Roof	71
4.4	Water Tank	72
4.4.1	Water Tank Safety	72
4.4.2	Introduction	72
4.4.3	Daily Inspection	73
4.4.3.1	Tank Integrity	73
4.4.3.2	Pressure Regulator Valve	73
4.4.3.3	Pressure Relief Valve	74
4.4.4	Daily Operation	74
4.4.5	Vehicle Handling Characteristics	74
4.4.6	Water Tank Decal Identification	75
4.4.7	Water Tank Operation	75

4.4.7.1 Filling the Tank76

4.4.7.2 Pressurizing the Water Tank 76

4.4.7.3 Depressurizing the Water Tank78

4.4.7.4 Draining the Water Tank.....79

PREVENTIVE MAINTENANCE

1.0 PREVENTIVE MAINTENANCE.....81

 1.1 DOT Pre-Trip81

2.0 PREVENTIVE MAINTENANCE INTERVALS81

3.0 DAILY PREVENTIVE MAINTENANCE CHECKS87

 3.1 Hydraulic System.....87

 3.1.1 Hydraulic Oil Level.....87

 3.1.1.1 Temperature / Level Sight Gauge87

 3.2 Electrical System.....89

 3.2.1 Lighting System89

 3.3 Pneumatic System.....89

 3.3.1 Coalescing Filter89

 3.4 Mechanical System90

 3.4.1 Refuse Vehicle Body and Components90

 3.4.2 Tailgate Seal90

 3.5 Operation.....90

 3.5.1 Refuse Vehicle Controls90

3.6 Trash Behind the Pack/Eject91

3.7 Safety Signs92

4.0 PROPPING THE TAILGATE.....92

 4.7.1 Engaging the Standard Tailgate Prop.....93

 4.7.2 Disengaging the Standard Tailgate Prop.....95

 4.7.3 Engaging the Hinge Design Tailgate Prop.....96

 4.7.4 Disengaging the Hinge Design Tailgate Prop.....98

5.0 CANOPY LIFT/LOWER.....99

 5.1 Procedure for the Manual Canopy Lift Design.....99

 5.2 Procedure for the Pneumatic Canopy Lift Design100

6.0 LUBRICATION.....102

 6.1 Daily Lubrication102

 6.2 Scheduled PM Lubrication.....105

TROUBLESHOOTING

1.0 INTRODUCTION107

 1.1 Onboard Diagnostics107

 1.2 Troubleshooting Chart109

INDEX

INDEX..... 111

1.0 Important Safety Information

READ AND UNDERSTAND THIS ENTIRE MANUAL BEFORE OPERATING, REPAIRING, OR ADJUSTING YOUR MCNEILUS EQUIPMENT.

THOSE WHO USE AND MAINTAIN THIS EQUIPMENT MUST BE THOROUGHLY TRAINED AND FAMILIAR WITH THE PRODUCT.

IF INCORRECTLY USED OR MAINTAINED, THIS EQUIPMENT CAN CAUSE SEVERE INJURY.

Always keep this manual in a location where it is readily available for persons who operate or maintain the product. Additional copies of this manual are available from McNeilus Truck and Manufacturing, Inc. Please contact McNeilus Truck and Manufacturing, Inc. if you require additional manuals or if you have any questions about the information in this manual, this product, or safe operating procedures.

THESE SAFETY PROCEDURES ARE FOR YOUR OWN PROTECTION.

Do not operate this equipment until you have read its contents thoroughly. Read and understand the Waste Collection Vehicle Safety Guide that is placed in the vehicle's cab. Please contact McNeilus Truck and Manufacturing, Inc. if you require assistance.

Should operators of this equipment have a reading or learning disability, dyslexia, or other such condition, they must be assigned a mentor/trainer to read and explain to them the entire contents of this manual as well as the safety guidelines,

danger, caution, and warning safety signs on this unit. Such individuals should not be allowed to operate this equipment until they thoroughly understand all of these materials. Failure to do so can result in serious injury or death.

Refer to your company's safety rules and procedures. Safety and safe working procedures must be followed at all times.

Perform your company's Lockout/Tagout procedure. If your company does not have a Lockout/Tagout procedure, follow OSHA 1910.147 and 1910.146 Confined Space as appropriate.

1.1 Battery Disconnect Switch

If the vehicle is equipped with a battery disconnect switch, it is located near the battery box. Use the battery disconnect switch when performing any maintenance so the vehicle cannot accidentally be started.

1. Turn the battery disconnect switch (Figure 3, Item 1) counterclockwise so the hole on the switch aligns with the hole in the bracket (Figure 3, Item 2).
2. Install the safety lockout device ring (Figure 4, Item 1) through the holes on the battery disconnect switch and the bracket.
3. Install a padlock (Figure 4, Item 2) onto the safety lockout device ring, lock it, and put the key in your pocket. If more than one person is working on the vehicle, each person must install his or her own padlock.

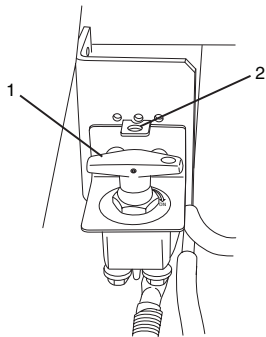

Figure 3

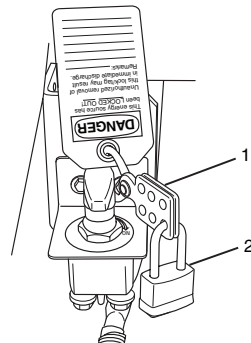

Figure 4

1.1.1 Battery Cable Disconnect

If the vehicle is not equipped with a battery disconnect switch, disconnect the negative (black) battery cable first, then disconnect the positive (red) cable.

⚠ WARNING

For trucks without a battery disconnect switch, to prevent accidental vehicle start-up, which could cause death or serious injury, disconnect battery cables (negative cable first) before proceeding.

Disconnect negative (-) battery cable first. If positive (+) cable should contact ground with negative (-) cable connected, the resulting sparks can cause a battery explosion, which could result in death or serious injury.

1.2 Safety Equipment

Some McNeilus Refuse Trucks come equipped with a five pound Fire Extinguisher, which has a rating of B:C, and a Reflective Warning Triangle Kit containing three triangles.

The fire extinguisher may already be mounted to the refuse vehicle, otherwise it is temporarily placed into the cab of your truck along with the reflective triangle kit.

If you are supplying your own fire extinguisher, it must comply with DOT FMCSA regulation 173.309 and 393.95 for rating and placement on the vehicle.

You are responsible for permanent mounting of this equipment. The fire extinguisher is required to be securely mounted to prevent sliding, rolling, or vertical movement. The placement and mounting location of the reflective triangles are at your discretion.

1.3 Reporting Safety Defects

If you believe that your vehicle has a defect which could cause a crash or could cause injury or death, you should immediately inform the National Highway Traffic Safety Administration (NHTSA) in addition to notifying McNeilus Truck and Manufacturing, Inc., and the chassis manufacturer.

If NHTSA receives similar complaints, it may open an investigation, and if it finds that a safety defect exists in a group of vehicles, it may order a recall and remedy campaign. However, NHTSA cannot become involved in individual problems between you, your dealer, McNeilus Truck and Manufacturing, Inc., or the chassis manufacturer.

To contact NHTSA, you may call the Vehicle Safety Hotline toll-free at 1-888-327-4236 (TTY: 1-800-424-9153); go to <http://www.safercar.gov>; or write to: Administrator, NHTSA, 400 Seventh Street, SW., Washington, DC 20590. You can also obtain other information about motor vehicle safety from <http://www.safercar.gov>.

2.0 Safety Notices

Safety notices are one of the primary ways to call your attention to potential hazards.



Safety Alert Symbol

THIS SAFETY SYMBOL INDICATES IMPORTANT SAFETY MESSAGES IN THIS MANUAL.

WHEN YOU SEE THIS SYMBOL, CAREFULLY READ THE MESSAGE THAT FOLLOWS.

BE ALERT TO THE POSSIBILITY OF PERSONAL INJURY OR DEATH.

The following safety notices are used throughout this manual.



DANGER

Danger indicates an imminently hazardous situation which, if not avoided, will result in death or serious injury. Danger is used in the most extreme situations.



WARNING

Warning indicates a potentially hazardous situation which, if not avoided, could result in serious injury or death.



CAUTION

Caution indicates a situation that might result in property damage.

SAFETY NOTICE

OPERATOR'S INSTRUCTION

The “signal words” of DANGER, WARNING, and CAUTION have specific meanings to alert you to the relative level of hazard.

Take the safety notices seriously. If you do not understand them or have questions about them, call McNeilus Truck and Manufacturing, Inc at 888-686-7278.

3.0 Product Safety Information

Read, understand, and follow the safety guidelines and heed dangers and warnings listed below and contained in this manual as well as on the refuse vehicle itself to promote reliable operation and prevent serious personal injury.

Contact McNeilus Truck and Manufacturing, Inc. at 888-686-7278 if you require assistance or have questions.

3.1 Safety

WARNING

Safety decals must be replaced anytime they are damaged, missing, or cannot be read clearly. Failure to have proper decals in place can result in serious injury or death. If you require safety decals, please contact McNeilus Truck and Manufacturing, Inc. at 888-686-7278.

WARNING

The Packer must not be modified in any way without authorization from McNeilus Truck and Manufacturing, Inc. Modifications may not comply with safety standards, including ANSI safety standards, and may result in serious personal injury. Please contact McNeilus Truck and Manufacturing, Inc. at 888-686-7278 if you require assistance.

WARNING

Wear Personal Protective Equipment (PPE) such as hard hats, safety glasses or goggles, sturdy gloves, hearing protection, steel toed boots, and snug fitting sturdy long-sleeve shirt and long pants when operating or maintaining the Packer. Reflective clothing is recommended for drivers and employees while packing during hours of darkness. Serious injury can result without proper PPE.

⚠️ WARNING

Operating, servicing, and maintaining this vehicle or equipment can expose you to chemicals including exhaust, carbon monoxide, phthalates, and lead, which are known to the state of California to cause cancer and birth defects or other reproductive harm. To minimize exposure, avoid breathing exhaust, do not idle the engine except as necessary, service your vehicle or equipment in a well ventilated area and wear gloves or wash hands frequently when servicing. For more information, go to www.p65warnings.ca.gov.

⚠️ WARNING

Read, understand, and follow all aspects of OSHA 1910.146 Confined Space and Permit-Required Confined Space. Check your local and state regulations.

Information is found in the Safety section of this manual.

Failure to follow regulations may cause serious personal injury or death.

3.2 Cab Operation**⚠️ DANGER**

If the Packer comes into contact or close proximity with a power line or there is any arcing, stay in the truck cab and keep away from the metal parts of the unit. Do not let anyone come close to the truck. Do not attempt to jump clear of the truck. Stay in the cab. The power company must disconnect the power before you can safely leave the cab.

Minimum clearance from power lines:

50,000 Volts or Less	4 Feet
50,000 + Volts	10 Feet
345,000 - 750,000 Volts	16 Feet

Know the clearance of overhead obstructions. Never drive the Packer under any overhead obstruction. Failure to do so may result in damage to the Packer body or truck, and may result in serious personal injury or death.

 **DANGER**

If chassis is equipped with a stand-up drive position, use stand-up position only during refuse pick-up or collection activities for distances of less than 2/10 mile (0.32 km). Failure to heed this warning may result in serious personal injury or death.

 **DANGER**

DO NOT operate vehicle in excess of 20 MPH from stand-up position. Failure to do so can result in serious personal injury or death.

 **DANGER**

Always drive defensively. Never exceed posted speeds. Use lower speeds when going around curves, corners, or freeway on/off ramps. You are carrying a high center of gravity load. Failure to comply can lead to a roll over or other loss of control of the vehicle resulting in serious personal injury or death.

 **WARNING**

Operators must comply with Employee Responsibilities as outlined in ANSI Z245 and state, federal, and other safety and transportation regulations (e.g. OSHA, DOT, Motor Carrier, and FMVSS) when operating this refuse vehicle. Failure to comply may result in serious personal injury or death.

 **WARNING**

Be sure all non-operator personnel are at least 20 feet (6 meters) away from all areas of the Packer.
Serious personal injury or death may occur.

 **DANGER**

Make sure the area above the vehicle is clear of objects and power lines before raising the arm.
Serious personal injury or death may occur.

 **DANGER**

Never attempt to clear a jammed Packer or container lift, enter a body or open an access door unless power is shut down, LOCKOUT/TAGOUT procedures have been complied with, and the employee is authorized, trained, and competent to perform such activities. Failure to comply may result in serious personal injury or death.

 **WARNING**

Keep access door closed when in operation. Do not open access door unless:

1. Engine is stopped.
2. Key is removed from ignition
3. Hydraulic pressures are relieved.
4. OSHA LOCKOUT/TAGOUT Regulations are complied with.

Failure to heed these instructions/warnings may result in serious personal injury or death.

 **WARNING**

Never walk or stand behind vehicle while it is backing up. Failure to heed these instructions/warnings may result in serious personal injury or death.

 **WARNING**

Never climb on windshield guard (if equipped). This is not a ladder. If equipped, use the ladder provided on the body to access the top of the vehicle. Failure to comply may result in serious personal injury or death.

⚠ WARNING

Be sure all non-operator personnel are clear of the area around the Packer before operating the Packer. Remain attentive at all times when operating the controls. Watch the mirrors for activity. Never back up the Packer unless and until you are completely sure it is safe. Use a spotter/observer and/or get out and check yourself, if necessary, to ensure it is safe to do so. Thoroughly understand the controls before operating the Packer. Failure to heed this warning may result in serious personal injury or death.

⚠ WARNING

Before opening the tailgate, be sure you have adequate clearance above the tailgate to prevent contact with buildings, electrical lines, and any other overhead obstructions. Failure to comply can cause damage to the vehicle and serious personal injury.

⚠ WARNING

Always keep hands and feet and other parts of your body clear of revolving or moving parts. Failure to comply can cause serious injury.

⚠ WARNING

The Packer and chassis should never be overloaded. Do not exceed the manufacturer's recommended gross vehicle weight. Do not overload the Packer and chassis. Gross weights must meet federal, state, and local laws. Failure to comply can cause serious injury.

⚠ WARNING

If refuse is spilled on the cab shield, only use an extendable handled rake or broom to remove the refuse. Never climb on the cab shield.
A fall from the cab shield may cause serious personal injury or death.

⚠ CAUTION

Be sure to drain the water tank, hoses, and pipes when operating in temperatures below freezing.

Failure to drain the system may cause damage to equipment.

⚠ CAUTION

If chassis is equipped with a battery disconnect switch, it must be turned off anytime the equipment is parked overnight, in a shop, or out of service for any extended period of time.

Failure to do so may result in a fire and personal injury or property damage.

⚠ CAUTION

The installation procedure must be followed when installing a carry can.

Failure to follow all these steps may cause serious personal injury or equipment damage.

3.3 Maintenance

SAFETY NOTICE

Perform your company's Lockout/Tagout procedure. If your company does not have a Lockout/Tagout procedure, follow OSHA 1910.147 and 1910.146 Confined Space as appropriate.

⚠ DANGER

LOCKOUT/TAGOUT procedures must be followed when working on this equipment including, but not limited to, cylinders being changed or maintained. Failure to heed these instructions/warnings can result in serious personal injury or death.

 **DANGER**

If the hydraulic or electrical system on the Packer fails to operate for any reason, call a competent technician to repair the problem. Never let any untrained or incompetent personnel attempt to fix any problems or malfunctions that may occur. If you are not trained or do not have the competence, never attempt to fix any problems or malfunctions that may occur. Never alter the original equipment manufacturer's design.

 **WARNING**

If equipped with optional camera or object detection system, do not rely exclusively on the camera or object detection system. Follow all other safe driving procedures. Failure to heed this warning may result in serious personal injury or death.

 **WARNING**

Operators must comply with Employee Responsibilities as outlined in ANSI Z245 and state, federal, and other safety and transportation regulations (e.g. OSHA, DOT, Motor Carrier, and FMVSS) when operating this refuse vehicle. Failure to comply may result in serious personal injury or death.

 **WARNING**

Be sure all non-operator personnel are at least 20 feet (6 meters) away from all areas of the Packer. Serious personal injury or death may occur.

 **WARNING**

No passenger is allowed in the cab unless a manufacturer's approved passenger seat and seat belt are provided. Serious injury or death can result.

⚠ WARNING

At the landfill or when operating off-road, use the lowest transmission gear and proceed at low speed (3 mph maximum). Failure to comply can cause serious injury.

⚠ WARNING

It is important that the pump ON indicator light is working. No damage will be done to the hydraulic system if the Packer is driven with the pump in the ON position. However, the controls will function if accidentally bumped. This can cause serious injury or death.

⚠ DANGER

Make sure the area above the vehicle is clear of objects and power lines before raising the arm. Serious personal injury or death may occur.

⚠ CAUTION

Always check indicator lights in the chassis cab or on the control panel at the front of the Packer. Replace bulbs or lights when required. (Note: All models may not have indicator lights.) Failure to inspect indicator lights may lead to more serious conditions.

⚠ CAUTION

Stow arms, forks, and container in hopper at the lowest height during transit. Be sure containers are stored at their lowest level in the hopper.

Failure to do so may result in a collision with bridges, overhead power lines, etc.

⚠ CAUTION

Use caution when raising the arm assembly with a container.

 **CAUTION**

The tailgate must be completely open before raising the body or damage to the rear bumper may occur.

 **CAUTION**

If you detect a problem with any control function, it must be repaired immediately. **DO NOT** operate the Packer with malfunctioning controls. Damage to property or equipment may occur.

3.4 Outside Operation

 **DANGER**

Never attempt to clear a jammed Packer or container lift, enter a body or open an access door unless power is shut down, LOCKOUT/TAGOUT procedures have been complied with, and the employee is authorized, trained, and competent to perform such activities. Failure to comply may result in serious personal injury or death.

 **WARNING**

If a container is dropped in the hopper, call maintenance for assistance in removing the container from the hopper.

Failure to do so may result in serious personal injury or death.

 **DANGER**

Auxiliary pusher or tag axles must be supported with jack stands, blocks, or similar devices while being serviced or maintained to prevent serious personal injury or death if auxiliary axle drops unexpectedly. Failure to do so may result in serious personal injury or death.

 **DANGER**

Use the three-point rule when climbing the ladder. Failure to heed may cause serious personal injury.

 DANGER

Do not climb on ladder while body is tilted or truck is in motion.
Serious personal injury can occur due to a fall.

 WARNING

Inspect ladder bolts every 30 days for wear and replace if necessary.
Failure to do so may result in serious personal injury or death.

 DANGER

Verify that the body props are fully seated in the pockets on the frame.
Serious personal injury or death may occur.

 DANGER

Crush hazard. Verify that the body props are properly positioned around the rods of the cylinders.
Serious personal injury or death may occur.

 DANGER

PACKER BODY MUST BE EMPTY and body props employed when servicing Packer body in the raised position. Body props are meant to support only the empty body. Never overload.

Failure to empty body or employ body props may cause serious personal injury or death.

 DANGER

Stand clear when the tailgate is in motion and during the unloading cycle. Do not stand under or cross under the raised tailgate.
Serious personal injury or death may occur.

 DANGER

Whenever the tailgate is in a raised position, it must be securely propped or blocked so it cannot fall on anyone.
Serious personal injury or death may occur.

 **DANGER**

Never attempt to use extraneous sources of power or extraneous machines to overcome a malfunctioning system.

Never override with overhead cranes, forklifts, jacks, etc. or alter or modify systems or equipment that may be malfunctioning.

Failure to heed these instructions/warnings can result in serious personal injury or death.

 **WARNING**

Daily inspections should be performed on the Packer. This includes proper operation of the controls, hydraulic systems, electrical systems, optional cameras are clean and working, camera lens is clean, lighting system including turn signals, back up alarm, brake lights, clearance lights, head lamps, tail lamps, safety equipment, and work lights are all operational. The Packer's air system must operate properly and have no leaks. Water and moisture should be drained from the Packer's air system daily. Failure to ensure all systems are operating properly can result in serious personal injury or death.

 **WARNING**

Do not wear watches, rings, and jewelry while working with electrical and mechanical equipment. These items can be hazardous and can cause serious and painful injuries if they come into contact with electrical wires, moving parts, or hydraulic equipment.

 **WARNING**

Use only the access door for entry to the Packer. Remember to follow the LOCKOUT/TAGOUT procedures when entering the Packer body. Only exit the Packer body through the access door.

 **WARNING**

If equipped with optional camera, camera lens must be kept clean at all times to help achieve good monitor pictures. Failure to heed this warning may result in serious personal injury or death.

 **CAUTION**

Correct all identified deficiencies BEFORE operating the Packer. Failure to correct deficiencies may cause damage to equipment.

 **WARNING**

Electrical wiring, battery wiring, and electrical cable must be inspected on a daily basis for cuts, abrasions, damage, aging, improper clearance and along the frame for hidden damage. If you find electrical wiring or electrical cable with any such adverse conditions or damage, they must be replaced with electrical wiring or electrical cable of equivalent specifications before the Packer is returned to service. Failure to properly inspect and maintain your Packer may result in serious personal injury or death.

 **WARNING**

When working on the Packer, the wheels must be blocked, the parking brake on, LOCKOUT/TAGOUT procedures in effect, and the keys out of the truck's ignition. Failure to do so may result in serious personal injury or death.

⚠ WARNING

Anytime a tailgate is raised in the shop or for maintenance, the tailgate must be supported to prevent the tailgate from coming down unexpectedly. Never allow anyone to work around or enter the tailgate area unless the tailgate is raised and supported! Failure to follow this procedure can result in serious injury or death.

⚠ WARNING

Do not repair or weld steel or aluminum water tanks. Inspect the water tank for rust or corrosion every 30 days. Inspect the water tank under the straps, on the exterior, and on the interior by removing the flopper. If any rust or corrosion is found, replace the water tank with an OEM water tank from McNeilus. Failure to maintain water tanks may result in serious personal injury or death.

⚠ WARNING

Never place yourself between the tailgate and the body. Always engage both tailgate props when performing maintenance or inspections in or around the open tailgate area.

Failure to engage both tailgate props may result in serious personal injury or death.

⚠ WARNING

Packer must be disabled by the following steps before proceeding.

1. Place transmission in NEUTRAL.
2. Apply chassis parking brake.
3. Shut engine OFF.
4. Remove chassis ignition key and maintain in personal possession.
5. Turn chassis BATTERY switch OFF.

Failure to disable the Packer may result in serious personal injury or death.

⚠ CAUTION

Disconnect battery before welding on body. Failure to do so might result in personal injury or damage to property or equipment.

⚠ CAUTION

Never attempt to prop a body or tailgate unless completely empty. Never walk or work under a raised body or tailgate unless props are in place. Failure to do so may result in serious personal injury or equipment damage.

3.5 Hydraulics

Call McNeilus Truck and Manufacturing, Inc. at 888-686-7278 anytime you have questions concerning hydraulic hoses, tubes, or pipes.

⚠ DANGER

Hydraulic systems operate under very high pressure. Hydraulic fluid escaping from a pressurized system can penetrate unprotected body tissue. Never inspect for hydraulic leaks with bare hands or other exposed body parts. As a minimum, wear leather gloves and use cardboard or wood to inspect for leaks. If leaks are present, relieve pressure and allow system to cool prior to servicing. If injured by escaping hydraulic oil, contact a physician immediately. Serious complications may arise if not treated immediately.

 **WARNING**

Hydraulic hoses and tubing must be inspected on a daily basis for leaks, cuts, abrasions, damage, aging, improper clearance, and along the frame for hidden damage. If you find hoses with any such adverse conditions or damage, they must be replaced before the vehicle is returned to service! Failure to properly inspect and maintain your vehicle may result in serious personal injury or death.

 **WARNING**

Hydraulic systems are hot. **DO NOT TOUCH!** Serious personal injury or death may result from hot oil. When you have completed working on the hydraulic systems, thoroughly clean any spilled oil from the equipment. Do not spill any hydraulic fluid on the ground. Clean any hydraulic fluid from your skin as soon as you have completed your maintenance and repairs. Dispose of used oil and filters as required by law.

 **WARNING**

The hydraulic cylinders can be holding a function in a certain position when the engine is OFF. An example of this would be a function being held in the lift or partial lift position by the cylinders. If a hydraulic line is removed or the hydraulic circuits or controls are being worked on, gravity may allow the function being held in position to drop. All workers and personnel must remain clear of these areas when working on or operating the McNeilus equipment. Block and secure all applicable devices and functions before beginning work or operation. Failure to comply with this can result in serious injury or death.

 **WARNING**

Hydraulic hoses have the SAE ratings marked on the hose to assist in selecting the correct hose. Replacement hydraulic hose and fitting components must be supplied by the same manufacturer to prevent serious injury or death. An example: Brand “A” hose and brand “B” fitting will not normally be compatible.

 **WARNING**

Do not heat hydraulic tubing. The carbon content of this steel tube is such that if heated for bending, and either water or air is quenched, the tubing may lose its ductility and thereby be subject to failure under high pressure or hydraulic shock conditions. Serious injury can result. Damaged or leaking tubing must be replaced before the Packer is returned to service. Please contact McNeilus Truck and Manufacturing, Inc. at 888-686-7278 if you require assistance or have questions.

 **WARNING**

Hydraulic systems operate under high pressure. Only qualified, experienced people properly trained in hydraulic system maintenance should attempt repairs or troubleshoot hydraulic systems. Use the proper tools and equipment when servicing the hydraulic system. Failure to comply can cause serious injury. Please contact McNeilus Truck and Manufacturing, Inc. at 888-686-7278 if you require assistance.

 **WARNING**

Increasing hydraulic pressure beyond the recommendations may result in serious damage to the Packer or serious personal injury or death and may void the Packer Warranty.

⚠ WARNING

All hydraulic pressures must be relieved from the hydraulic system prior to removing any components from the system to prevent oil from spraying or functions or systems from falling. Failure to follow this procedure can result in serious personal injury or death.

⚠ WARNING

Do not steam clean or pressure wash the pump or hydraulic hose. Cleaning the pump with a high pressure washer or steam cleaning may damage the pump's seals and allow water to enter the hydraulic system. Cleaning the hydraulic hose with a high pressure washer or steam cleaning will damage the hose's outer covering and steel braid and lead to premature failure. The pump and hydraulic hose should be wiped with a clean lint-free cloth rather than washed.

⚠ WARNING

Hydraulic components can be heavy. Use caution while lifting these components. Serious personal injury can be avoided with proper handling of the components.

3.6 Electrical

⚠ WARNING

Proximity switches must remain functional for safe operation of the Packer. If a switch does not work, it must be replaced immediately with an OEM switch before the Packer returns to service. Failure to comply can result in serious injury or death. Contact McNeilusTruck and Manufacturing, Inc. at 888-686-7278 for assistance if required.

4.0 Safety Signs

The following safety signs are found on your refuse collection system and warn of hazards related to the use of this equipment. Read and understand all safety signs before operating this equipment.

NOTE

Depending on the Packer configuration and optional equipment, the actual location of decals and/or placards may vary slightly from the examples shown.

If any safety signs on the equipment are not clearly readable, call McNeilus Parts and Service at 888-686-7278 or visit www.streetmartparts.com to order replacements. Use only McNeilus replacement safety signs.

The table below contains part numbers for the individual safety signs. See the Figures in this section for safety sign locations.

NOTE

Specifications, appearance, and part numbers for safety decals are subject to change without notice.

No.	Part Number	Qty.	Comments
1	9590.614298	2	
2	1107479	1	
3	9090.614542	2	
4	9190.614301	2	
5	9090.614430	2	
6	9190.614299	3	
7	9190.614302	1	
8	9090.614548	1	
9	780.214618	1	
10	9190.614305	1	
11	1140908	1	
12	9790.614269	1	
13	9090.614412	1	
14	780.214500	1	
15	9090.614541	1	
16	1318804	1	
17	9790.614306	1	
18	9090.614526	1	
19	9790.614308	1	
20	9790.601933	1	
21	9790.614277	1	

No.	Part Number	Qty.	Comments
22	9790.614286	1	
23	9790.614296	1	
24	9190.614263	3	
25	9790.614261	1	
26	9190.614271	4	
27	9790.614274	1	
28	9190.614292	3	
29	9090.614583	1	If equipped.
30	1108358	2	
31	9090.614392	2	
32	1172954	1	
33	9090.614559	1	
34	9190.614285	1	
35	9090.614547	1	If equipped.
36	9790.660903	1	
37	9090.612453	1	
38	9190.614270	1	
39	9090.614448	2	
40	9790.614338	1	
41	1107478	3	
42	1108425	1	

No.	Part Number	Qty.	Comments
43	1109764	1	
44	1225787	2	
45	1326487	1	If equipped. Not shown.
46	1327929	1	
47	1327934	1	
48	1324145	1	
49	1329260	1	
	1329261		
50	1449162	1	If equipped.
51	1104395	1	If equipped with water tank.
52	1327939	1	If equipped with water tank.
53	1397069	1	
54	1404116	3	
55		1	
56	1265704	Varies	
57	1260913	Varies	
58	1260914	Varies	
59	1133532	1	If equipped. Location varies.
60	1140666	1	If equipped. Location varies.
61	1490253	1	If equipped. Location varies.

4.1 Safety Sign Location

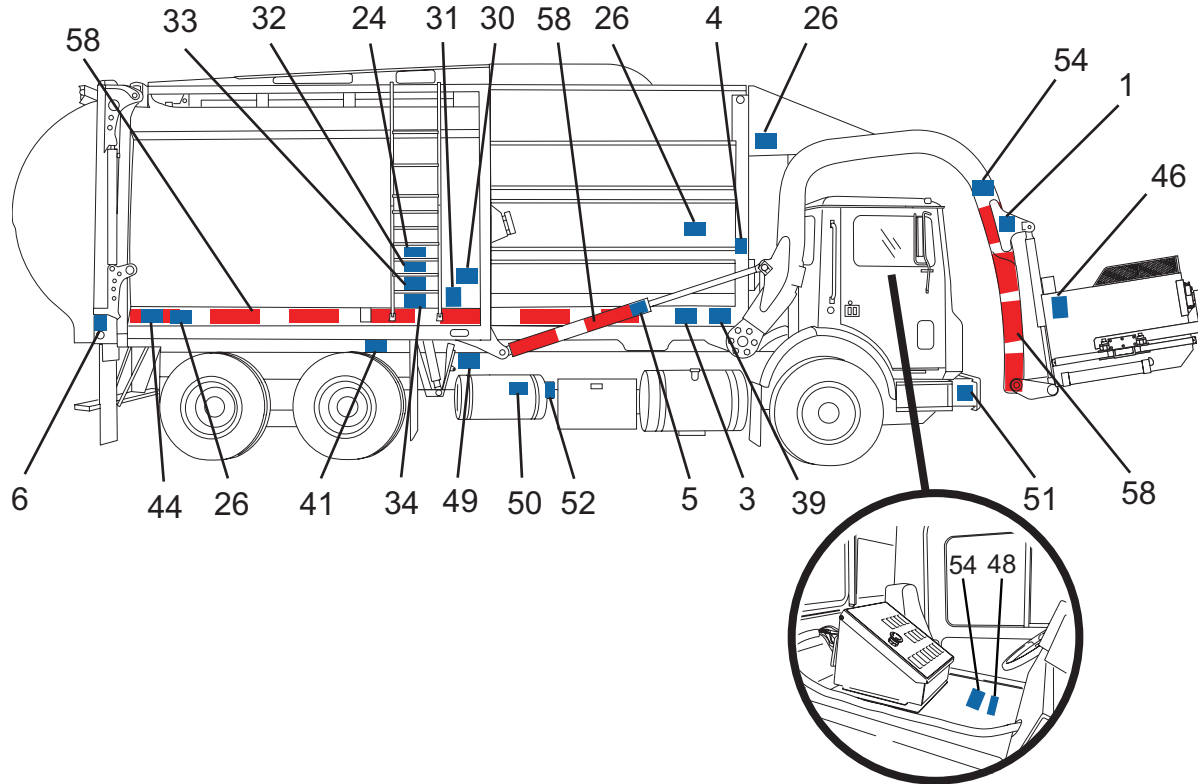

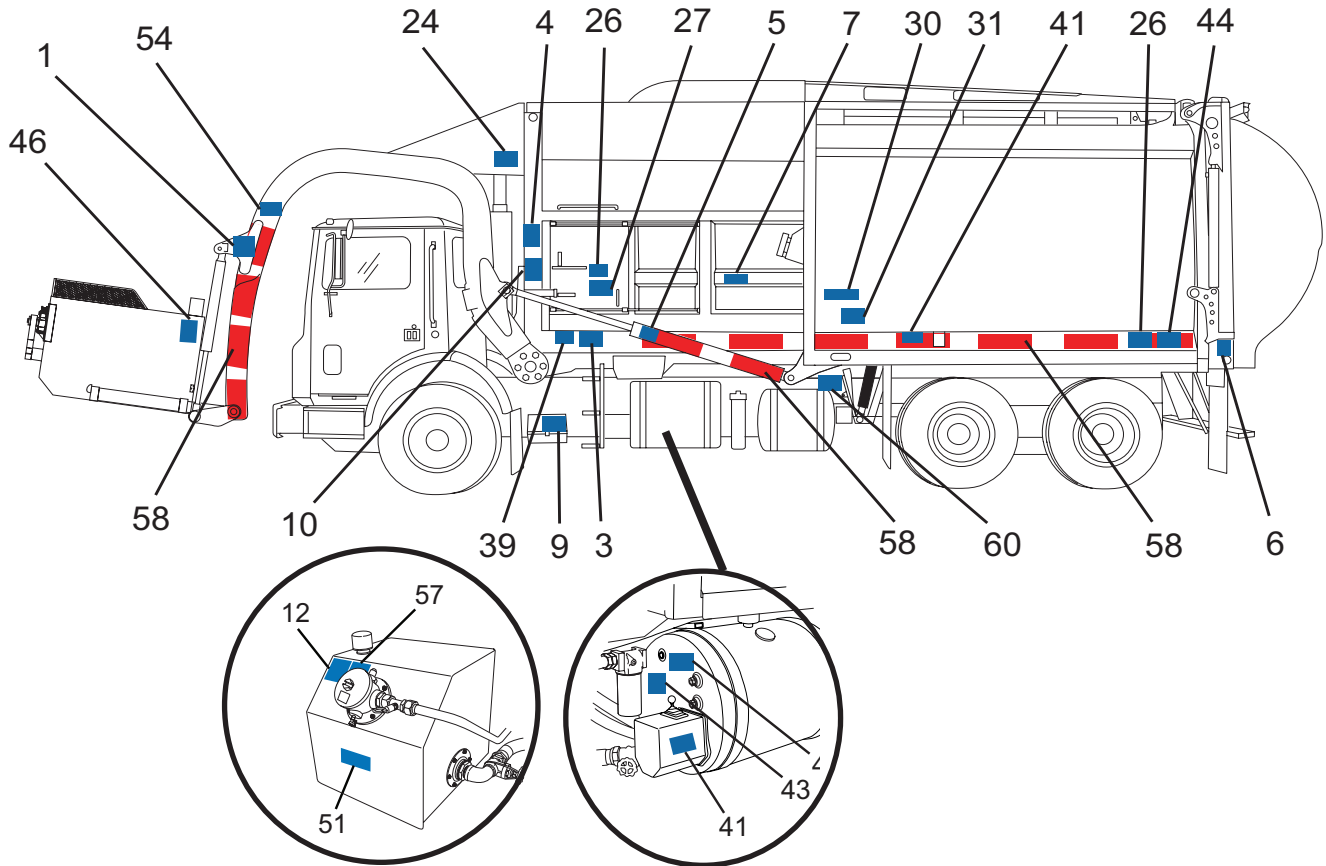

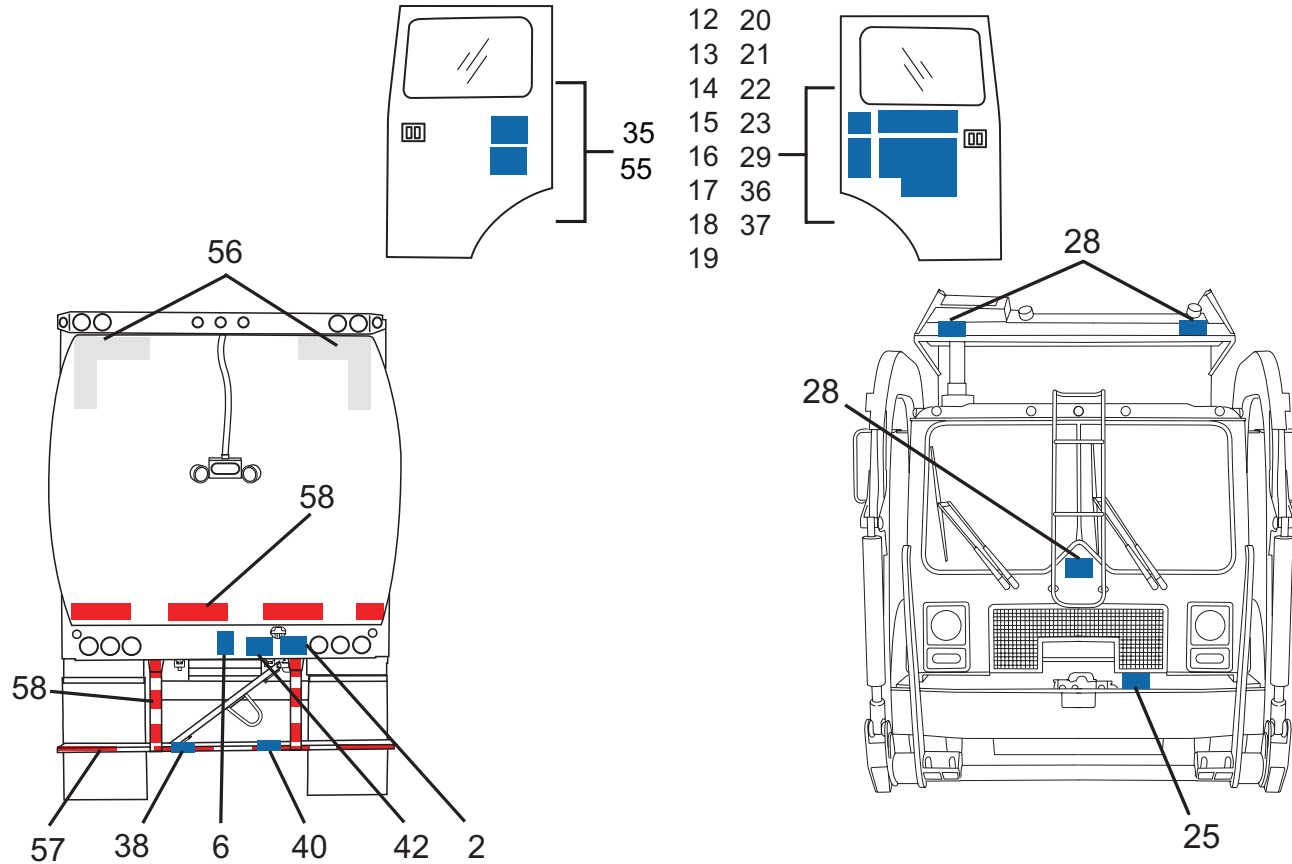

1.0 Exterior Systems Arrangement

1.1 Street Side View

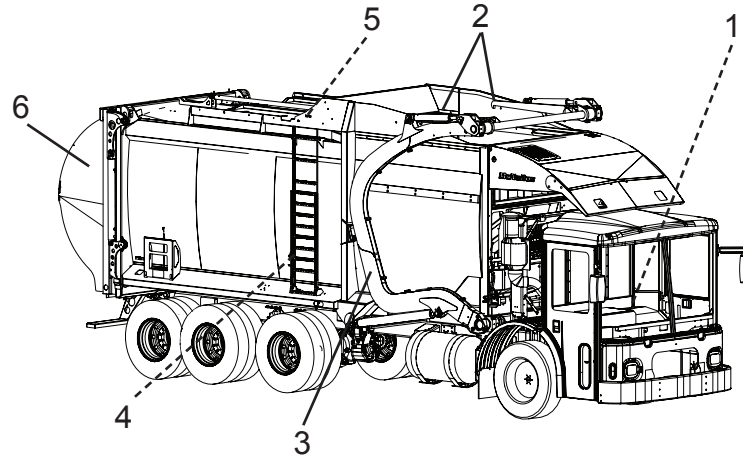

Ref. No	System Description
1	Cab Control Box and Joystick
2	Fork Assembly
3	Arm Assembly
4	Pack/Eject
5	Top Door
6	Tailgate

1.2 Curb Side View

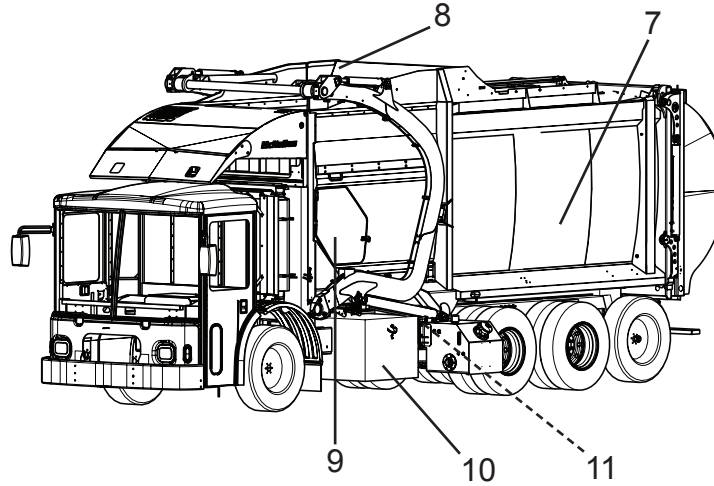

Ref. No	System Description
7	Body
8	Hopper
9	Side Access Door
10	Hydraulic Oil Reservoir
11	Service Lift Cylinders (Optional)

1.3 S-Type Container Specifications

Only lift containers that are compatible with ANSI Z245.6-2008, type S containers. Check to make sure the container meets the dimensional requirements before lifting (Figure 3).

No.	Description	Specification									
1	Width of the fork receiver area at the inside surface of the outboard pocket walls.	Min: 79 in. Max: 80 in.									
2	Width at the top of the container, including all lids, hinges and hinge rods.	Max: 78 in.									
3	Width of the fork receiver area at the inside surface inboard pocket wall, including bump plates.	Max: 73-1/2 in.									
4	Height of the pocket between the inside surfaces of the top and bottom wall.	Min: 4 in.	5	Extension of the bump plates below the inside surface of the bottom pocket wall.	Min: 25 in.	6	Height of the pocket above ground at the inside surface of the top wall.	Min: 25 in.	7	Height from inside top pocket wall to the top leading edge of the container, over all lids and hinges.	Max: 48 in.
5	Extension of the bump plates below the inside surface of the bottom pocket wall.	Min: 25 in.									
6	Height of the pocket above ground at the inside surface of the top wall.	Min: 25 in.									
7	Height from inside top pocket wall to the top leading edge of the container, over all lids and hinges.	Max: 48 in.									

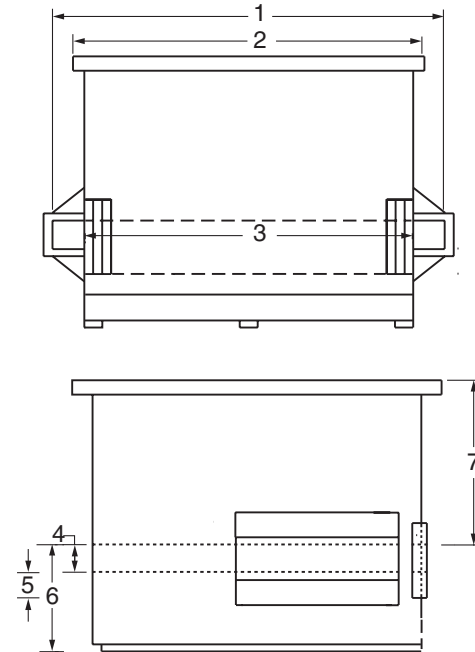

Figure 3

NOTES

1.0 Operating Procedures

WARNING

Be sure all non-operator personnel are at least 20 feet (6 meters) away from all areas of the Packer.
Serious personal injury or death may occur.

NOTE

Turn the pump ON and idle the truck for a minimum of five minutes before operating the hydraulic functions when the air temperature is 50° F (10° C) or below.

WARNING

Do not leave the truck unattended until the parking brake has been securely set and all reasonable precautions have been taken to prevent the movement of the truck. The operator must chock the truck wheels anytime he is away from the vehicle for an extended period of time. Wheel chocks are available for purchase from McNeilus Truck and Manufacturing, Inc. by calling 888-686-7278.

Failure to comply may result in serious personal injury or death or damage to equipment.

1.1 Start-Up Procedure

Before starting the vehicle, make certain that:

1. Battery switch is ON.
2. Daily checks have been completed and verified.

1.2 Warm-Up Procedure

At start-up of the equipment each morning, it is important to cycle through each of the main hydraulic circuits to be certain each circuit is functioning properly. Cycling through each operation also helps ensure that the hydraulic fluid is up to operating temperature and is present throughout the system.

**CAUTION**

If you detect a problem with any control function, it must be repaired immediately.

DO NOT operate the Packer with malfunctioning controls.

Damage to property or equipment may occur.

1. Cycle through each of the following operations:
Pack/Eject Functions - Cycle three (3) times.
Tailgate Functions - Cycle one (1) time.
Top Door Functions - Cycle three (3) times.
Fork and Arm Functions - Cycle ten (10) times.
2. After completing the cycle tests, inspect the refuse vehicle for any hydraulic leaks. If the leaks are detected, correct them **BEFORE** the refuse vehicle is placed into actual operation.

1.3 Traveling Procedure - Standard

Before beginning travel to the next site, be sure that all hydraulic functions are in their HOME positions. This means that the:

1. Tailgate is fully closed.
2. The arms and forks must be positioned properly for travel.
3. The arms and forks can either be positioned with the forks raised and arms raised above the windshield (Figure 5, Item 1), or with the forks tucked and the arms fully raised (Figure 6, Item 2).
4. Turn PUMP rocker switch OFF to disable hydraulic functions.
5. Turn all warning and strobe lights ON.

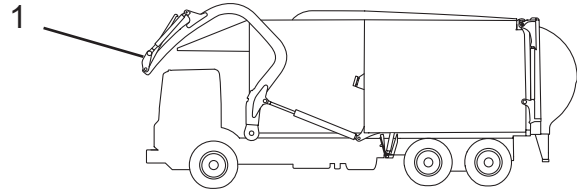

Figure 5

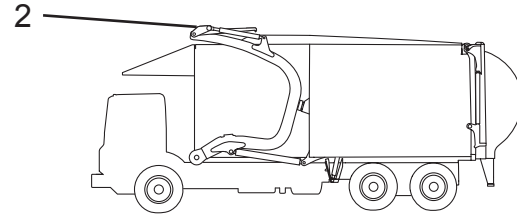

Figure 6

1.4 Traveling Procedure - Residential

Before beginning travel to the next site, be sure that all hydraulic functions are in their HOME positions. This means that the:

1. Tailgate is fully closed.
2. The arms and forks must be positioned properly for travel.
3. For a residential application equipped with a carry can, the arms must be fully raised with the carry can inserted into the hopper (Figure 7, Item 1). **Never travel to the next site with the can positioned low (Figure 8, Item 2). This position is for work only.**
4. Turn PUMP rocker switch OFF to disable hydraulic functions.
5. Turn all warning and strobe lights ON.

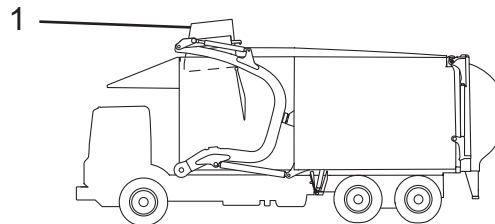

Figure 7

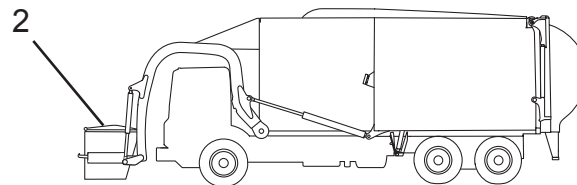

Figure 8

WARNING

Depending on what size carry can you use, verify the overall height of the truck with the carry can inserted into the hopper does not exceed the specified overall truck height listed on the height decal on the truck.

Failure to comply may cause serious injury or death or damage to equipment.

1.5 Preparation Before Starting Route

1. Turn battery disconnect ON.
2. If necessary, turn rear and side lights ON to enhance vision.
3. Turn pump rocker switch ON.
4. Activate all E-STOP buttons.

1.6 Neutral Interlock Test Procedure for Optional Neutral Interlock

 **WARNING**

Never disable neutral safety or interlocks. Failure to comply may result in serious injury or death or damage to equipment.

If equipped with the optional throttle momentary switch, follow this procedure weekly to ensure the proper operation of the neutral interlock. Before performing this procedure, the packer should be located outside and away from people, other vehicles, and buildings. Two people are required for this procedure.

1. Move the truck to an outside area away from people, other vehicles, and buildings. Clear a 50' area in the front and behind the truck in case the truck moves backward or forward while performing the following test. If the truck

moves backward or forward during the test, person #1 in the cab should apply the brakes and immediately disarm the throttle. If the truck moves backward or forward while performing the test, person #2 (the outside operator) should immediately release the throttle momentary toggle switch to allow it to return to the "off" position.

2. Place approved blocks on the rear wheels to prevent the truck from moving.
3. Person #1 should enter the truck cab, apply the parking brake, and start the truck engine, and remain in the cab.
4. Person #1 should ready the cab throttle momentary toggle switch, place the automatic transmission in reverse, and remain in the cab.
5. Person #2 should go to the optional outside control box and engage the throttle momentary toggle switch. The throttle should not engage unless the truck is in neutral.
6. Person #1 should place the automatic transmission in drive and remain in the cab.
7. Repeat step #5.
8. If the throttle engages with the transmission in reverse or drive, the truck may have a malfunctioning neutral switch or not have a neutral switch for the throttle system.
9. If the truck has a malfunctioning neutral switch, immediately remove the truck from service and call McNeilus Service Department immediately at 888-686-7278.

1.7 Refuse Loading Procedure

WARNING

Be sure all non-operator personnel are at least 20 feet (6 meters) away from all areas of the Packer.
 Serious personal injury or death may occur.

WARNING

If refuse is spilled on the cab shield, only use a extendable handled rake or broom to remove the refuse. Never climb on the cab shield.
 A fall from the cab shield may cause serious personal injury or death.

1. Make certain the top door is OPEN and the pack/eject is in the HOME position.
2. Lower the fork and arm assemblies into position to lift the container.
3. Position the vehicle in line with the container, and drive the vehicle forward until the forks are all the way through the container fork pockets (Figure 9).
4. Adjust the fork assembly so the container is level.

CAUTION

Use caution when raising the arm assembly with a container.

DANGER

Make sure the area above the vehicle is clear of objects and power lines before raising the arm.
 Serious personal injury or death may occur.

5. Raise the arm assembly until the fork assembly is visible at the top of the windshield.
6. Lower fork assembly to level the container.
7. Continue to raise the arm assembly until arm assembly reaches the arm stops.
8. Completely raise fork assembly to empty container.
9. Lower the fork assembly until the container has cleared the hopper and the forks are vertical.
10. Lower the arm assembly to return the container to the ground.
11. Adjust the fork assembly as needed to allow the vehicle to back away from the container.
12. Place the fork and arm assemblies in the travel position.

CAUTION

Do not operate pack and sweep with container in hopper.

Serious damage may result to the Packer.

13. Execute an AutoPack Function.
14. Close the top door.
15. Travel to the next pickup site.

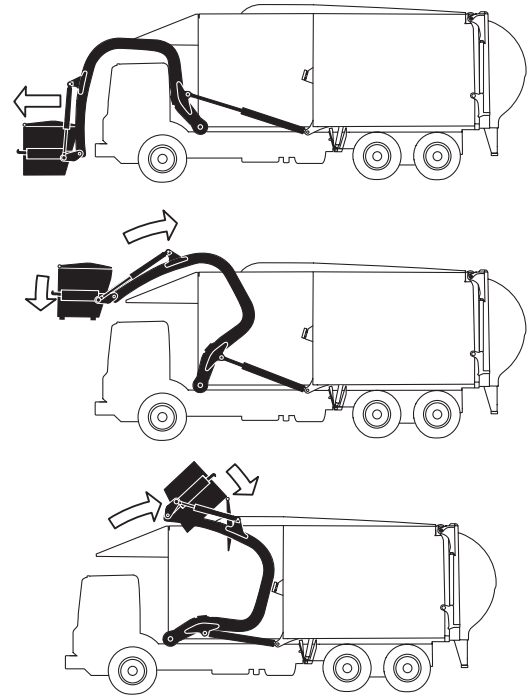

Figure 9

1.8 Refuse Empty Procedure

⚠ WARNING

**Be sure all non-operator personnel are at least 20 feet (6 meters) away from all areas of the Packer.
Serious personal injury or death may occur.**

⚠ DANGER

**Make sure the area above the vehicle is clear of objects and power lines before raising the arm.
Serious personal injury or death may occur.**

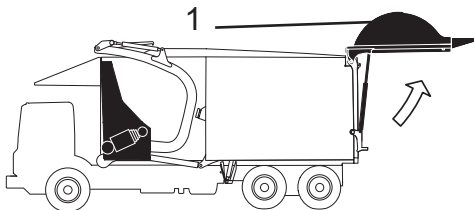

Figure 10

1. Position the rear of the refuse vehicle as appropriate.
2. Verify the top door is open, the fork and arm assemblies are in the travel position.

3. Open the tailgate fully (Figure 10, Item 1).
4. Extend the pack/eject to the rear (Figure 11, Item 1) of the body to eject the load.
5. Retract the pack/eject to the HOME position.
6. Lower the tailgate and prop for maintenance. (In the Preventive Maintenance section, see 4.7.1 Engaging the Standard Tailgate Prop.)

⚠ WARNING

Never place yourself between the tailgate and the body. Always engage both tailgate props when performing maintenance or inspections in or around the open tailgate area.

Failure to engage both tailgate props may result in serious personal injury or death.

7. Inspect and clean the tailgate seal and sealing areas of the body, and then fully close the tailgate.
8. Remove the props from the tailgate. (In the Preventive Maintenance section, see 4.7.2 Disengaging the Standard Tailgate Prop.)

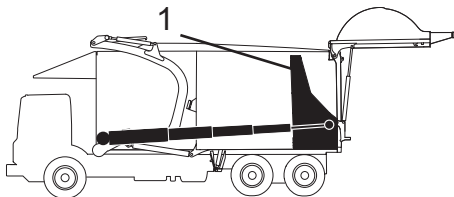

Figure 11

1.9 End of Day Checks

At the end of the day, make certain that:

1. Pack/Eject is fully retracted.
2. Fork and arm assemblies are fully raised.
3. Tailgate is fully closed.
4. Body (OPTIONAL) is fully lowered.
5. All equipment is properly shut down (see the Chassis Manual for more information on proper shut-down procedures for the engine).

2.0 Control Box and Instruments

NOTE

Control configurations and locations may vary depending upon customer ordered options.

Your Packer may not have all the features or options covered in this manual. You should pay careful attention to the instructions that pertain to your vehicle. If your vehicle is equipped with special equipment or options not covered in this manual, please contact McNeilus Truck and Manufacturing, Inc. at 888-686-7278.

The following figures and tables identify and describe the controls used on the equipment. Not all of the instruments and controls shown here are on your equipment. Items covering various models and options are illustrated.

To make sure you understand proper operating procedures, read this section and carefully practice with the controls and instruments to learn how to safely operate the equipment.

2.1 Cab Controls

The in-cab controls consist of in-dash controls or a control box (Figure 12, Item 1) and a joystick(s) (Figure 12, Item 2). There are several types of joystick options available. The dual-lever joystick option is shown.

No.	Position	Normal Use or Reading
1	Control Box	Controls refuse vehicle functions, lights, and options.
2	Joystick	Controls the arm and fork movements.

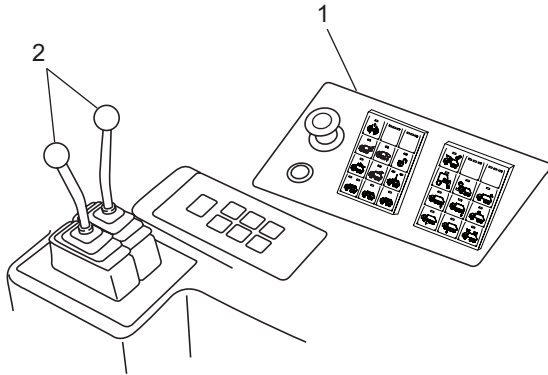

Figure 12

2.2 Control Box

The in-cab control box contains the E-STOP (emergency stop) button (Figure 13, Item 1), buttons for the refuse vehicle functions, lights, pump, and options (Figure 13, Item 2), and a red LED warning light (Figure 13, Item 3).

No.	Position	Normal Use or Reading
1	E-STOP Button	Disables all hydraulic and electric refuse vehicle functions.
2	Switches and LED Lights	Controls refuse vehicle functions, lights and options, and displays error codes and status of operations.
3	Red LED Warning Light	If light is on or flashing, it indicates an unsafe condition. Look at the LED lights on the control box to determine what the unsafe condition is. Under normal operating conditions, the light will be off.

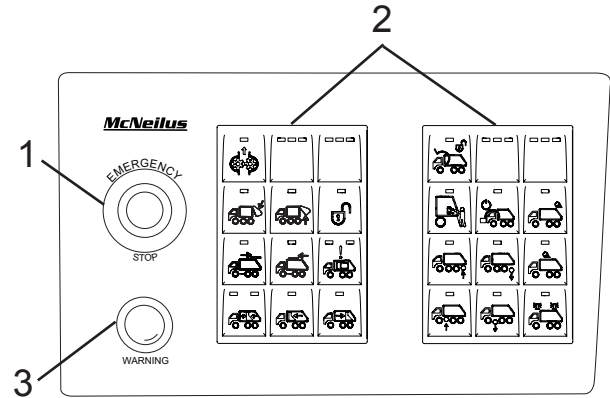

Figure 13

2.2.1 Refuse Vehicle Button Functions

Refuse vehicle functions, lights, some accessories, and options are operated by the buttons on the control box (Figure 14). Accessories and options vary depending on your model.

No.	Position	Normal Use or Reading
1	PUMP Button	Press to activate hydraulic functions. The indicator light above the button will be green when the pump is on. Press again to disable hydraulic functions.
2	TAILGATE CLOSE Button	Press and hold button to close the tailgate. You must also press and hold the ACTIVATE button while holding the TAILGATE CLOSE button. The indicator light above the button will be green when the tailgate is fully closed.
3	TAILGATE OPEN Button	Press and hold button to open the tailgate. You must also press and hold the ACTIVATE button while holding the TAILGATE OPEN button.
4	ACTIVATE Button	Press and hold the button to enable the tailgate functions.

No.	Position	Normal Use or Reading
5	TOP DOOR OPEN Button	Press and hold the button to open the top door. The indicator light above the button will be green when the top door is fully open.
6	TOP DOOR CLOSE Button	Press and hold the button to close the top door. The indicator light above the button will be flashing red when the top door is fully closed.
7	AUTOPACK / EJECT Button	Press this button to start the autopack.
8	RETRACT Button	Press this button to retract the pack/eject to the HOME position.
9	EXTEND Button	Press this button to extend the pack/eject. Pressing the button will stop the auto pack mode if active.
10	ARM OVER BODY OVERRIDE Button	Press and hold to override the interlock to operate the pack/eject when arms are above the body.
11	REMOTE Button	Press the button to enable the outside control box. The indicator light above the button will be green. Press the button again to disable the outside control box. The indicator light above the button will turn off.

No.	Position	Normal Use or Reading
12	RESIDENTIAL MODE Button	Press the button to enable the auto dump and residential controls when using the Dual Lever Joysticks. Press the button again to disable the auto dump.
13	REAR WORK LIGHT Button (OPTIONAL)	Press the button to turn on the rear work lights. Press the button again to turn off the rear work lights. The truck must be moving less than 10 mph for the rear work lights to come on.
14	TAG AXLE RAISE Button (OPTIONAL)	Press the button to raise the tag axle.
15	TAG AXLE LOWER Button (OPTIONAL)	Press the button to lower the tag axle.
16	WORK LIGHT Button (OPTIONAL)	Press the button to turn on the work lights. Press the button again to turn off the work lights.
17	PUSHER AXLE RAISE Button (OPTIONAL)	Press the button to raise the pusher axle.

No.	Position	Normal Use or Reading
18	PUSHER AXLE LOWER Button (OPTIONAL)	Press the button to lower the pusher axle.
19	STROBE LIGHT Button (OPTIONAL)	Press the button to turn on the strobe lights. Press the button again to turn the strobe lights off. With the “strokes on with pump” option, the button will not turn the strobe lights off when the pump is on.
20	SIDE DOOR Button	None functional button. Warning light only. See 2.2.2 LED Indicator Light Functions for more information.

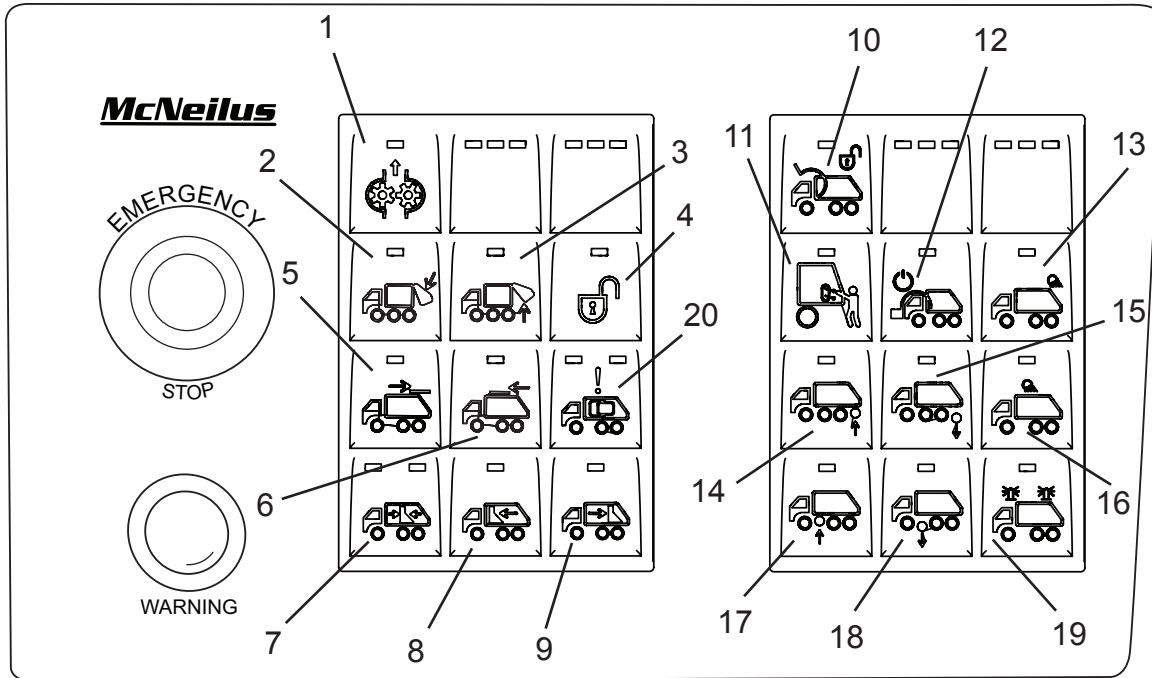

Figure 14

2.2.2 LED Indicator Light Functions

The LED indicator lights are used to display the status of various functions and operations (Figure 15). When the ignition switch is first turned on, the lights will perform a self-test which will light all the lights for a few seconds.

No.	Position	Normal Use or Reading
1	Pump On LED	The LED will be green when the pump is on.
2	Error Code LED	There are six LEDs that will be on or off depending on the error code. If any of these LEDs are lighted, refer to the error code decal located on the cab center console. Note: To enter the diagnostic mode, press and hold both buttons with the exclamation icon for five seconds.
3	Tailgate Closed LED	The LED will be green when the tailgate is fully closed. The LED will flash red when the tailgate is in the process of being closed.
4	Tailgate Open LED	The LED will flash red if the tailgate is not fully closed.

No.	Position	Normal Use or Reading
5	Activate LED	If a button is pressed that requires the ACTIVATE button to be pressed, but the ACTIVATE button was not pressed, the amber LED will flash, indicating the ACTIVATE button must also be pressed.
6	Top Door Open LED	The LED will be green when the top door is fully open.
7	Top Door Close LED	The LED will flash red when the top door is in the fully closed position.
8	Side Door LED	When the side door is fully closed, the LED will be off. When the side door is opened, it activates the E-STOP, shuts off the hydraulic pump, and the red LED will flash. The hydraulic pump icon and the amber LED above it will also flash.
9	AutoPack LEDs	The two red LEDs will flash when the pack/eject is in the autopack mode.
10	Pack/Eject Retract LED	The LED will be green when the pack/eject is retracted into the HOME position.

No.	Position	Normal Use or Reading
11	Pack/Eject Extend LED	The red LED will light when the pack/eject is extended. The pack/eject will not extend to the full eject mode unless the tailgate is fully open.
12	Arm Over Body Override LED	The LED will be green when the arm is in the over body override mode.
13	Remote Button LED	The LED will be green when the REMOTE button is activated. The outside control box is now operational.
14	Residential Controls Mode LED	The LED will be green when the arm is in the Residential Controls Mode.
15	Rear Work Light LED	The LED will be green when the rear work lights are on.
16	Tag Axle Up LED	The LED will be green when the tag axle is in the fully RAISED position.
17	Tag Axle Down LED	The LED will be green when the tag axle is in the fully DOWN position.
18	Work Light LED	The LED will be green when the work lights are on.
19	Pusher Axle Up LED	The LED will be green when the pusher axle is in the fully RAISED position.

No.	Position	Normal Use or Reading
20	Pusher Axle Down LED	The LED will be green when the pusher axle is in the fully DOWN position.
21	Strobe Light LED	The LED will be green when the strobe lights are on.

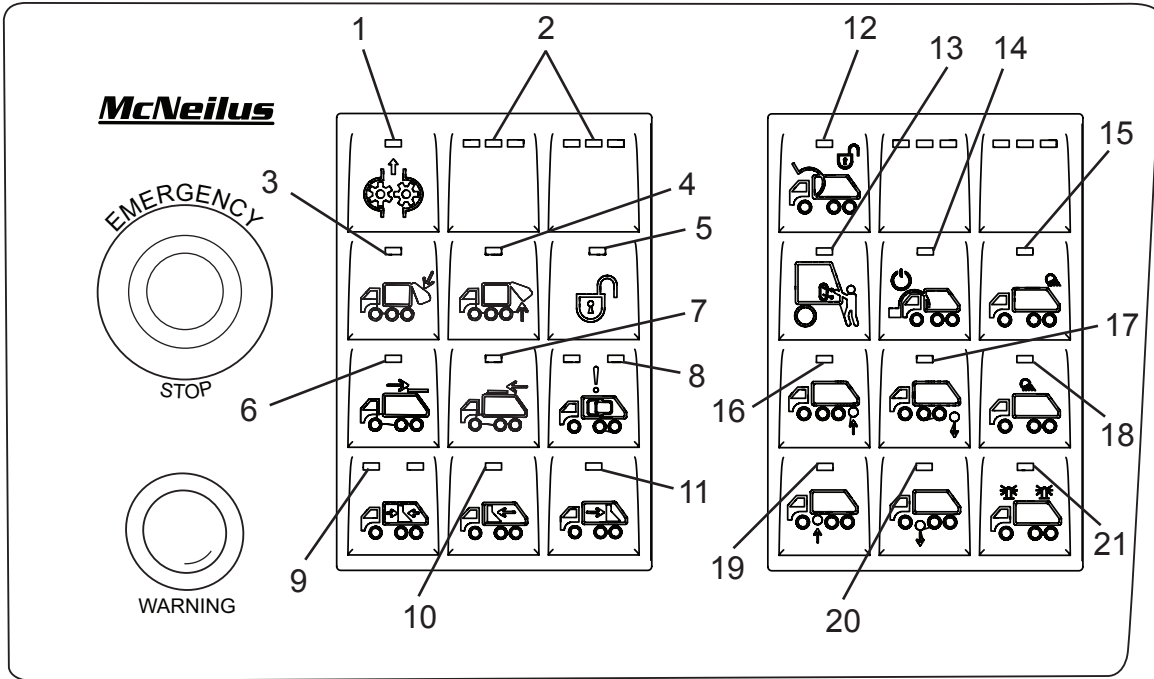

Figure 15

2.2.3 Fuse Block

The fuse block protects the in-dash controls from an overloaded condition. The fuse block is located on the refuse vehicle behind the cab. Open the cover (Figure 16, Item 1) to gain access to the fuses (Figure 17).

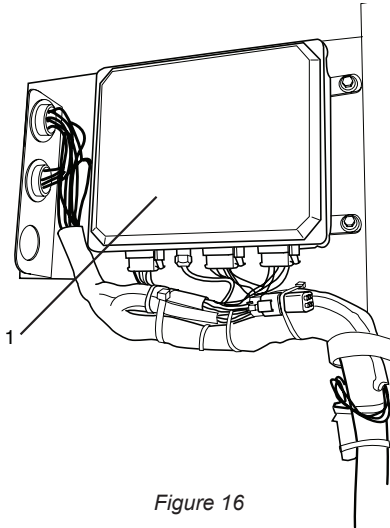

Figure 16

No.	Amp	Description
1	5	Proximity Switch Power Fuse
2	15	Front Lights Fuse

No.	Amp	Description
3	5	Control Power
4	10	Tag Axle/Reverse Alarm Fuse
5	5	Pusher Axle Fuse
6	10	3G Power Auxiliary Power Fuse
7	5	Module Power Fuse
8	15	Strobe Light Fuse
9	15	Rear Lights Fuse
10		Spare
11	10	Hydraulic Controls Fuse
12		E-STOP Power Relay
13	10	Hydraulic 1 Fuse
14	5	Top Door Fuse
15	5	Hydraulic 2 Fuse
16		Spare
17		Front Work Lights Relay
18		Rear Work Lights Relay
19		Strobe Lights Relay
20		Spare Relay
21		Ignition Relay 1
22	3	Module Memory Fuse
23		Ignition Relay 2

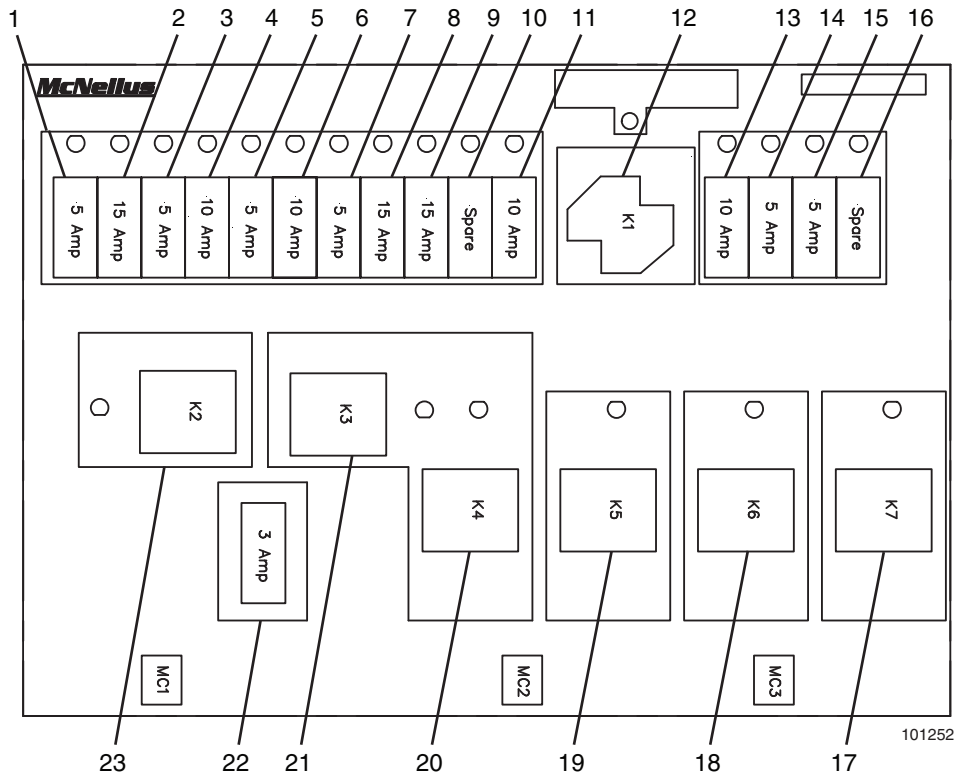

Figure 17

2.3 Arm and Fork Controls

There are three types of controls for the Arm and Fork Functions. There are two types of single lever joysticks available that enable the single joystick to operate both the Arm and Fork Functions. The second type of control is the dual lever in which one lever controls the Arm Functions and the other lever controls the Fork Functions.

WARNING

**Be sure all non-operator personnel are at least 20 feet (6 meters) away from all areas of the Packer.
Serious personal injury or death may occur.**

DANGER

**Make sure the area above the vehicle is clear of objects and power lines before raising the arm.
Serious personal injury or death may occur.**

CAUTION

Use caution when raising the arm assembly with a container.

2.3.1 Street Side/Curb Side Switch

When you have more than one joystick which can be operated from the Street Side or the Curb Side of the cab, the switch must be moved to the correct position.

When the toggle switch (Figure 18, Item 1) is in the middle, it is in the OFF position (Figure 18, Item 2). The joysticks will not function in the OFF position.

Move the toggle switch (Figure 18, Item 1) to the Street Side Joystick position (Figure 10, Item 3) for Street Side Joystick operation.

Move the toggle switch (Figure 18, Item 1) to the Curb Side Joystick position (Figure 18, Item 4) for Curb Side Joystick operation.

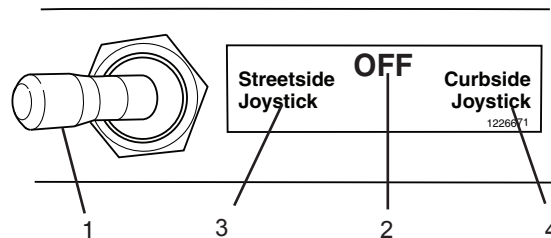

Figure 18

2.3.2 Single Lever Joystick Control

The single lever joystick (Figure 19) controls the movement of both the arm and fork assemblies.

The joystick is spring loaded and will automatically return to the middle (neutral) position when released.

Move the STREET SIDE/CURB SIDE switch to the position the controls will be operated from. (See Street Side/Curb Side Switch.)

Pull the joystick BACK (Figure 19, Item 1) to raise the arm assembly.

Push the joystick FORWARD (Figure 19, Item 2) to lower the arm assembly.

Push the joystick AWAY from the operator (Figure 19, Item 3) to lower the fork assembly.

Pull the joystick TOWARD the operator (Figure 19, Item 4) to raise the fork assembly.

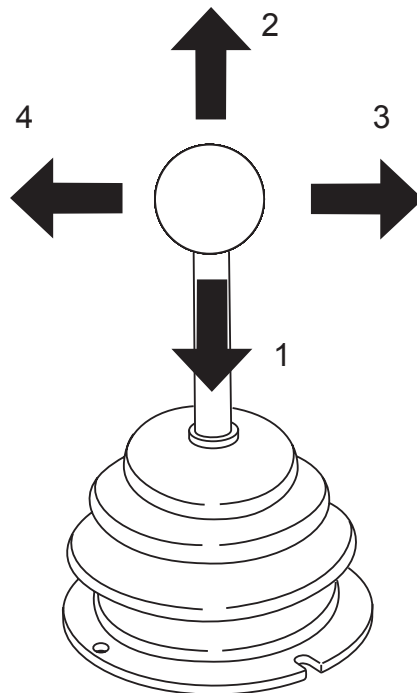

Figure 19

Figure represents view from street side in chassis cab.

2.3.3 Single Lever Joystick Control (Optional)

The joystick is spring loaded and will automatically return to the middle (neutral) position when released.

The single lever joystick (Figure 20) controls the movement of both the arm and fork assemblies.

Move the Street Side/Curb Side switch to the position the controls will be operated from and activate the Residential Controls switch.

Press in and hold the CENTER (Operator Presence) switch (Figure 20, Item 5) to activate the joystick.

Pull the joystick BACK (Figure 20, Item 2) to raise the arm assembly.

Push the joystick FORWARD (Figure 20, Item 1) to lower the arm assembly.

Push the forks LOWER button (Figure 20, Item 4) to lower the fork assembly.

Push the forks RAISE button (Figure 20, Item 3) to raise the fork assembly.

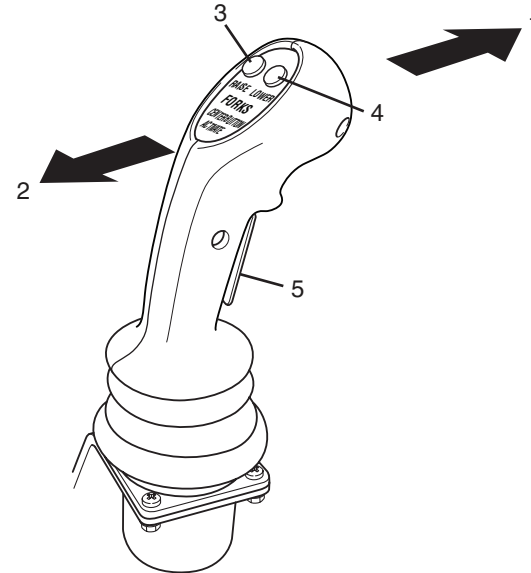

Figure 20

2.3.4 Dual Lever Controls (Optional)

NOTE

The **INSIDE** lever of the dual controls always controls the arm function. It does not matter whether it is mounted on the curbside or the streetside.

The **INSIDE** lever is always closest to the operator.

The Dual Lever controls consist of two separate levers. One lever controls the movement of the arm assembly. The other lever controls the movement of the fork assembly.

The control levers are spring loaded and will automatically return to the middle (neutral) position when released.

Move the Street Side/Curb Side switch to the position the controls will be operated from.

Pull the corresponding control lever **BACK** (Figure 21, Item 1) to raise the arm assembly.

Push the corresponding control lever **FORWARD** (Figure 21, Item 2) to lower the arm assembly.

Push the corresponding control lever **FORWARD** (Figure 21, Item 3) to lower the fork assembly.

Pull the corresponding control lever **BACK** (Figure 21, Item 4) to raise the fork assembly.

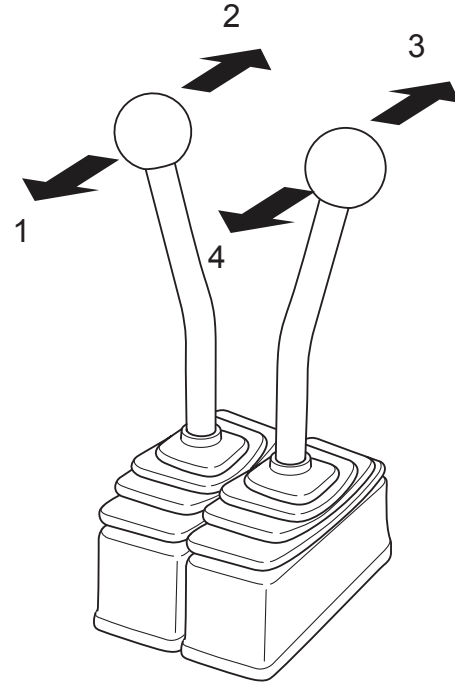

Figure 21

Figure represents view from street Side in chassis cab.

2.3.5 Auto Dump Single Lever

Press in and hold the CENTER (Operator Presence) switch (Figure 22, Item 3) to activate the joystick.

Pull the joystick back (Figure 22, Item 2) and hold to begin the auto dump function.

To return the container to the ground, push the joystick forward (Figure 22, Item 1) and hold.

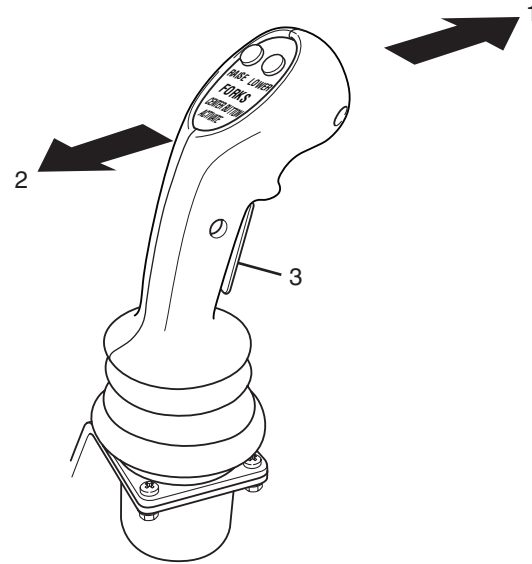

Figure 22

2.4 Outside Control Box (Optional)

The Arm, Fork, Pack/Eject, Throttle Advance, and E-STOP Functions can be operated from the outside control box (Figure 23). The REMOTE button on the in-dash control panel must be ON to enable the outside controls.

No.	Description	Normal Use or Reading
1	AUTO PACK/EJECT Switch	Press and hold the switch up to activate automatic cycling of Pack/Eject Function.
2	THROTTLE ADVANCE Switch	Press and hold the switch up to increase chassis engine RPM.
3	FORK Control Switch	Press and hold the switch to the left to raise fork assembly. Press and hold the switch to the right to lower fork assembly.
4	ARM Control Switch	Press and hold the switch to the left to raise arm assembly. Press and hold the switch to the right to lower arm assembly.
5	E-STOP Button	Disables all hydraulic, pneumatic, electric functions.
6	Operator Presence Button	Press and hold the button when using any of the outside control switches.

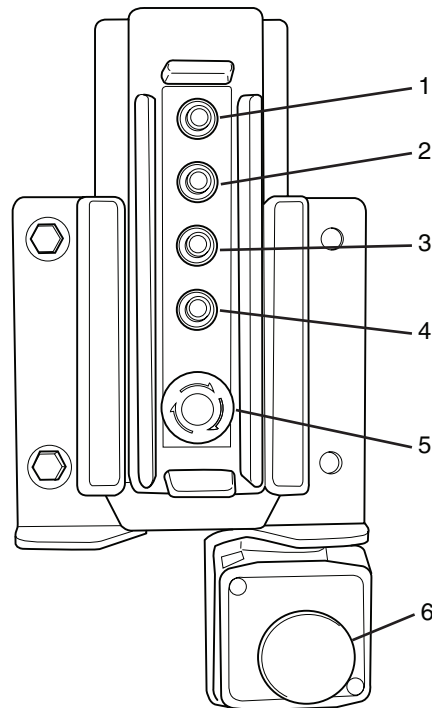

Figure 23

3.0 Control Functions

3.1 E-STOP (Emergency Stop) Function

Press any of the E-STOP buttons (Figure 24) to IMMEDIATELY DISABLE refuse vehicle and Hydraulic functions.

The E-STOP button is a safety function. Pressing the E-STOP button disables all refuse vehicle Electrical, Pneumatic, and Hydraulic functions.

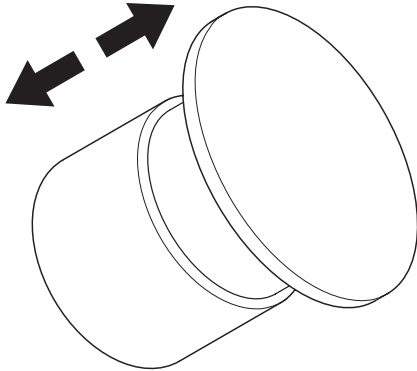

Figure 24

3.1.1 In-Cab Control Panel E-STOP Button

Pull up on the button to release the in-dash control panel E-STOP button (Figure 25, Item 1).

3.1.2 Outside Control Box E-STOP Button

Pull up on the button to release the outside control box E-STOP button (Figure 25, Item 2).

NOTE

All E-STOP buttons must be in the UP position before the refuse vehicle functions can be restored.

NOTE

If Packer functions are not operational, reset the controls by pulling up ALL of the E-STOP buttons and turning the pump back on.

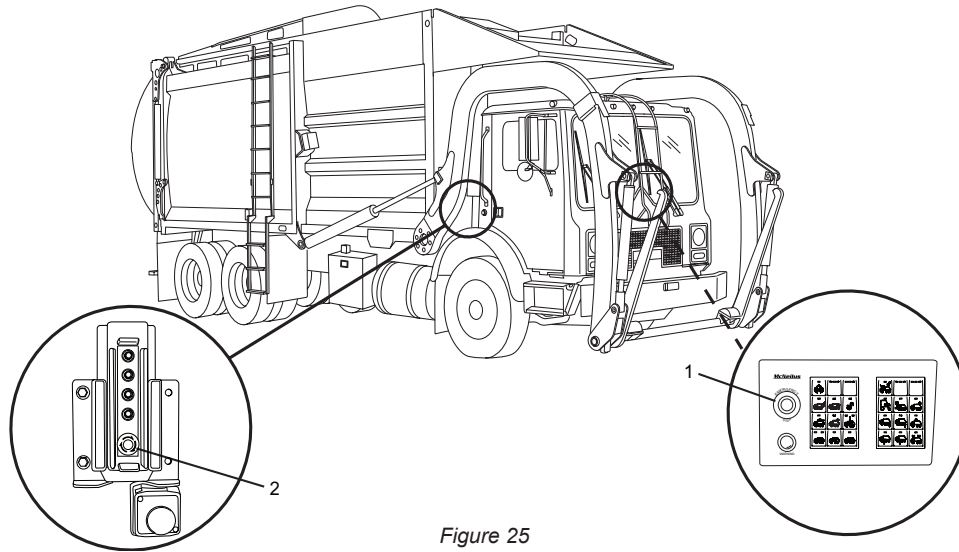

Figure 25

3.2 Pack/Eject Functions

The Pack/Eject Functions are controlled by two buttons located on the in-cab control panel. Automatic cycling of the Pack/Eject Functions is controlled by the AUTOPACK button. Manual cycling of the Pack/Eject Functions is controlled by the EXTEND button or the RETRACT button.



WARNING

**Be sure all non-operator personnel are at least 20 feet (6 meters) away from all areas of the Packer.
Serious personal injury or death may occur.**

Press the AUTOPACK button to activate automatic cycling of the Pack/Eject Functions. When activated, the pack/eject extends from the HOME position (Figure 26, Item 1) into the hopper until it reaches the EXTEND position (Figure 26, Item 2). The pack/eject then reverses direction and retracts until it returns to the HOME position.

NOTE

The automatic packing cycle can be interrupted by pressing any of the E-STOP buttons.

3.2.1 Automatic Cycling of Pack/Eject

Conditions

- Tailgate CLOSED indicator light must be green
- Side door indicator light must be off
- Top Door OPEN indicator light must be green
- Engine speed must be below 1600 rpm

3.2.2 Manual Cycling of Pack/Eject

Conditions

(Applies to Extend Function Only)

- Tailgate CLOSED indicator light must be green
- Side door indicator light must be off
- Top Door OPEN indicator light must be green
- Arms must be lowered below cab
- Engine speed must be below 1600 rpm

Manual cycling of the Pack/Eject Functions is controlled by the EXTEND button or the RETRACT button located on the in-cab control panel. With the tailgate CLOSED, the pack/eject can only travel to the EXTEND position (Figure 26, Item 2).

Press and hold the EXTEND button to manually control the extend movement of the pack/eject. When the button is released, the pack/eject will stop at its current position.

Press and hold the RETRACT button located on the in-cab control panel to retract the pack/eject. The pack/eject will retract to the HOME position (Figure 26, Item 1). When the RETRACT button is released, the pack/eject will stop at its current position.

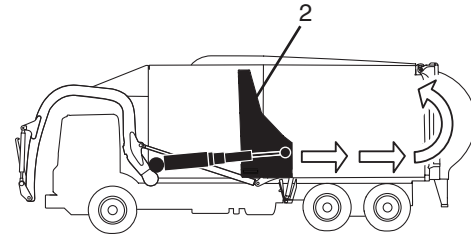
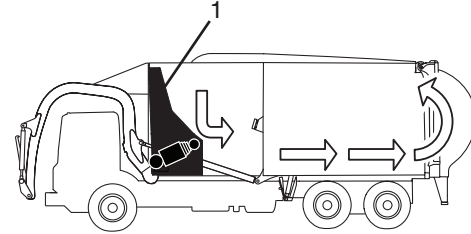

Figure 26

3.2.3 Manual Cycling with Tailgate Open

Conditions

(Applies to Extend Function Only)

- Side door indicator light must be off
- Top Door OPEN indicator light must be green
- Tailgate must be fully open
- Engine speed must be below 1600 rpm

When the tailgate is OPEN, the EXTEND button or the RETRACT button controls the Pack/Eject Functions, however, the pack/eject can travel into the body.

With the tailgate fully OPEN, the pack/eject will extend past the EXTEND position. The distance that the pack/eject extends into the body is determined by holding the EXTEND button.

While holding the EXTEND button, the pack/eject (Figure 27, Item 1) will extend to the rear of the body to eject the load.

Press and hold the RETRACT button to retract the pack/eject to the HOME position.

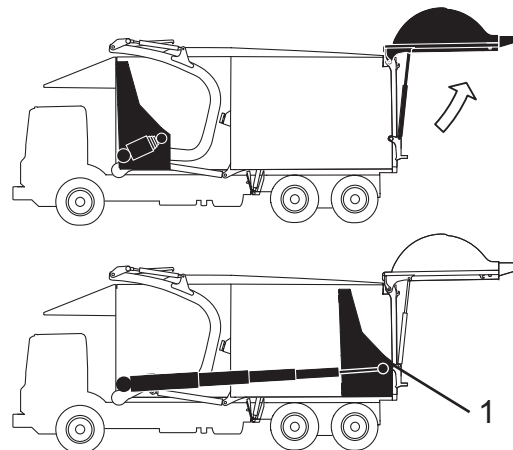

Figure 27

3.3 Arm Functions

The Arm Functions are controlled from the chassis cab or outside control box.

WARNING

Be sure all non-operator personnel are at least 20 feet (6 meters) away from all areas of the Packer.
Serious personal injury or death may occur.

DANGER

Make sure the area above the vehicle is clear of objects and power lines before raising the arm.
Serious personal injury or death may occur.

CAUTION

Use caution when raising the arm assembly with a container.

Conditions

- Side door indicator light must be off
- Top Door OPEN indicator light must be green
- Pack/Eject RETRACT indicator light must be green
- Engine speed must be below 1600 rpm

Use the arm controls to raise the arm assembly (Figure 28, Item 1).

Use the arm controls to lower the arm assembly (Figure 28, Item 2).

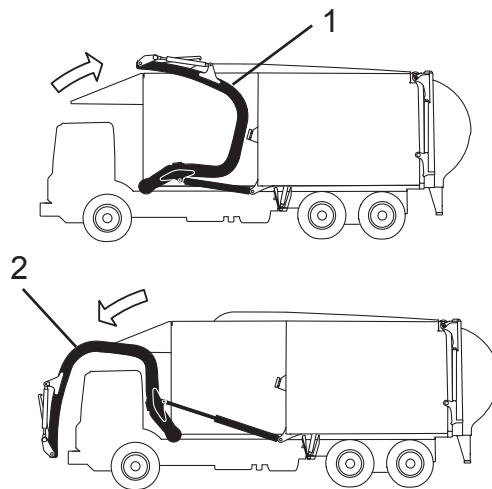

Figure 28

3.4 Fork Functions

The Fork Functions are controlled from the chassis cab or outside control box.

WARNING

**Be sure all non-operator personnel are at least 20 feet (6 meters) away from all areas of the Packer.
Serious personal injury or death may occur.**

DANGER

**Make sure the area above the vehicle is clear of objects and power lines before raising the arm.
Serious personal injury or death may occur.**

Conditions

- Side door indicator light must be off
- Engine speed must be below 1600 rpm

Use the fork controls to raise the fork assembly (Figure 29, Item 1).

Use the fork controls to lower the fork assembly (Figure 29, Item 2).

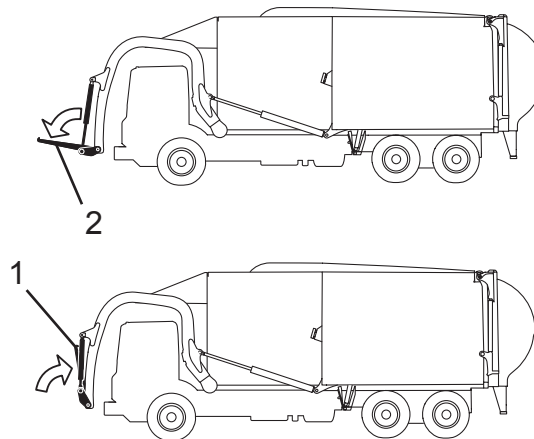

Figure 29

3.5 Auto Dump Functions (Optional)

With the Auto Dump Function, the fork assembly is automatically rotated when the arm assembly is raised or lowered. The fork assembly is rotated to avoid interference with the body canopy.

WARNING

**Be sure all non-operator personnel are at least 20 feet (6 meters) away from all areas of the Packer.
Serious personal injury or death may occur.**

DANGER

**Make sure the area above the vehicle is clear of objects and power lines before raising the arm.
Serious personal injury or death may occur.**

CAUTION

Use caution when raising the arm assembly with a container.

Conditions

- Side door indicator light must be off
- Top Door OPEN indicator light must be green
- Pack/Eject RETRACT indicator light must be green
- Engine speed must be below 1600 rpm

After the forks are positioned in the container, follow the procedure for Auto Dump controls on your refuse vehicle (see 2.3.5 Auto Dump Single Lever).

1. Turn on pump.
2. Turn on Residential Mode.
3. Pull and hold the joystick straight back.
4. The arm assembly will begin to raise with the container (Figure 30, Item 1).
5. As the arm assembly raises above the body (cab), the fork assembly will automatically lower to a level position (Figure 30, Item 2).
6. The arm assembly will start to raise until the fork assembly is fully raised and the container is in the DUMP position (Figure 30, Item 3).
7. Push and hold forward once load is dumped to lower can.
8. After the container is emptied, the fork assembly will begin to lower until the container is out of the hopper.
9. After the fork assembly stops, the arm assembly will begin to lower and place the container on the ground.

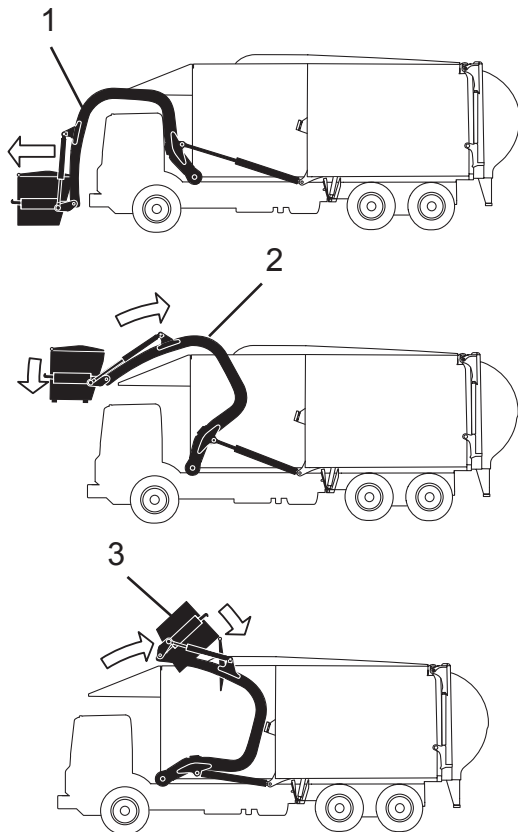

Figure 30

3.6 Tailgate Functions

The Tailgate Functions are controlled by the TAILGATE OPEN and CLOSE buttons and the ACTIVATE button located on the in-cab control box.

WARNING

Be sure all non-operator personnel are at least 20 feet (6 meters) away from all areas of the Packer.
 Serious personal injury or death may occur.

DANGER

Make sure the area above the vehicle is clear of objects and power lines before raising the arm.
 Serious personal injury or death may occur.

Conditions

- Side door indicator light must be off
- Engine speed must be below 1600 rpm

3.6.1 Open Tailgate

Press and hold the ACTIVATE and the OPEN TAILGATE buttons at the same time to open the tailgate (Figure 31, Item 1).

3.6.2 Close Tailgate

Press and hold the ACTIVATE and the CLOSE TAILGATE buttons at the same time to close the tailgate (Figure 31, Item 2).

NOTE

The warble alarm sounds when the tailgate is opening and remains on until the tailgate is closed.

The alarm does not sound if the ignition switch is OFF or any of the E-STOP buttons are pressed down.

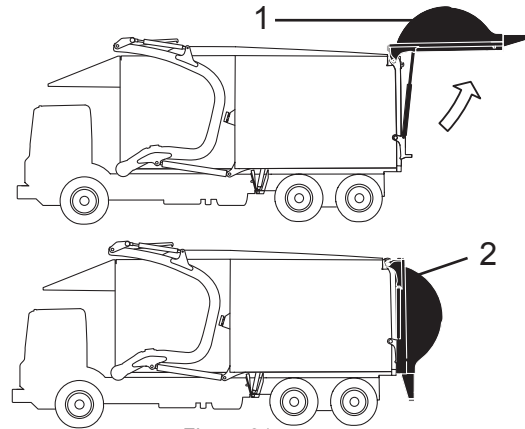

Figure 31

3.7 Top Door Functions

The top door functions are used to close off the refuse hopper during travel to keep trash from blowing out of the hopper. The Top Door functions are controlled by the TOP DOOR OPEN and CLOSE buttons on the in-dash/cab control panel.

⚠ WARNING

Be sure all non-operator personnel are at least 20 feet (6 meters) away from all areas of the Packer. Serious personal injury or death may occur.

Conditions

- Side door indicator light must be off
- Engine speed must be below 1600 rpm

⚠ CAUTION

Use the top door only to seal off the hopper area when traveling. The top door should not be used as a pack assist panel when using the Pack and Sweep function. Damage to the top door may result.

3.7.1 Open Top Door

Press and hold the TOP DOOR OPEN button to open the top door (Figure 32, Item 1).

3.7.2 Close Top Door

Press and hold the TOP DOOR CLOSE button to close the top door (Figure 32, Item 2).

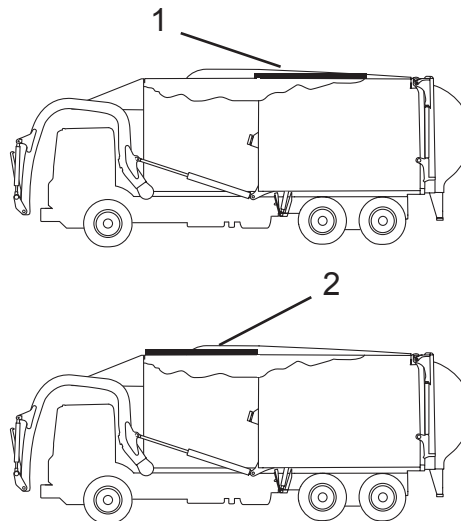

Figure 32

4.0 Optional Equipment

4.1 Residential Attachments

The residential application for a front loader requires the use of a carry can. The carry can is mounted and secured to the fork assembly. When the carry can is equipped with a cart tipper or automatic arm, the required hydraulic and electrical lines are routed down the curb side arm assembly with the connections (Figure 33) mounted on the fork assembly.

The routing of hydraulic and electrical lines from the connections to the carry can will vary with different models and manufacturers of carry cans.

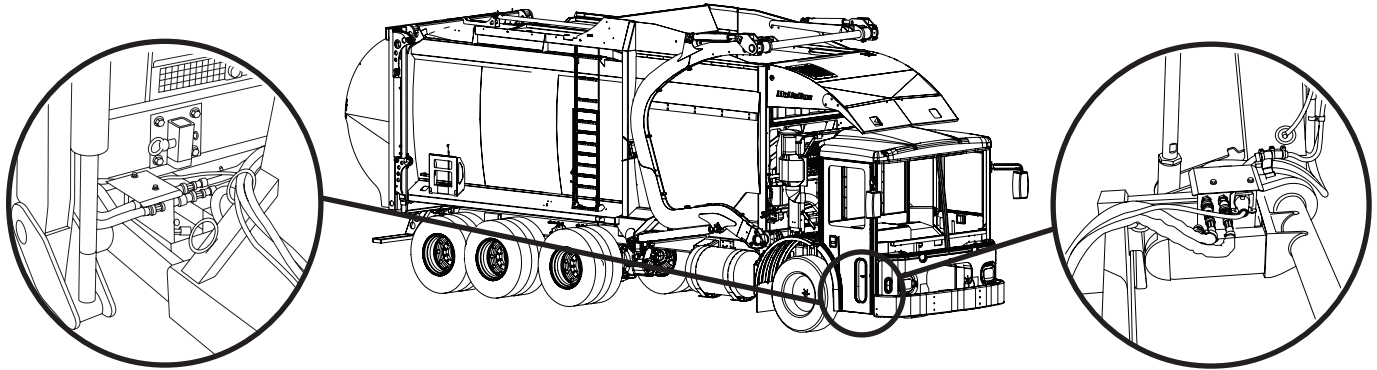

Figure 33

4.1.1 Installing a Carry Can



⚠ CAUTION

The installation procedure must be followed when installing a carry can.

Failure to follow all these steps may cause serious personal injury or equipment damage.

1. Always follow the mandated Lockout/Tagout procedures.
2. Always clear area around arm and fork area in front of the truck.
3. Fully raise arms to stow arms in hopper.
4. Remove truck key from ignition.
5. Install bumper arm rest pads and secure with pin and lock.
6. Clear the area, start truck, and lower arms.
7. Insert forks into carry can pockets.
8. Tip forks up slightly to correctly position carry can on forks.
9. Install carry can spacer tubes and retaining bolts (if applicable).
10. Remove truck key from ignition.
11. Attach carry can safety chain or strap to or around fork tube.
12. Attach hydraulic quick disconnects and electrical connections (if carry can has hydraulic tipper).
13. Start truck, clear the area, and verify the tipper works properly.
14. Reverse the above process to remove carry can.
15. Call McNeilus Truck and Manufacturing, Inc. at 888-686-7278 if you require further assistance or have questions.

4.2 Pusher Axle or Tag Axle

NOTE

The following information is for auxiliary axles installed by McNeilus Truck and Manufacturing, Inc. Refer to chassis manufacturer information for axle installed by the chassis manufacturer or a third party.

The auxiliary axle down force is controlled by regulated air pressure to the axle suspension air springs. The regulated air pressure is preset at the factory to a common pressure setting. Determine the actual regulated air pressure by driving the vehicle over a truck scale at the various weights the vehicle will be operated at up to the GVWR as shown on the Final Stage Manufacturer Label located on the driver's side cab doorjamb (see Section 2 in the Foreword). Adjust the regulated air pressure according to the auxiliary axle manufacturer's pressure/weight chart located in the cab information packet supplied with the vehicle. The air pressure gauge is located in the cab of the vehicle and may also be located outside of the cab.

Always follow your company's policies and procedures when adjusting the air pressure. If you have any questions, call McNeilus Parts and Service branches at 888-686-7278.

A tag axle (Figure 34, Item 1) is mounted in behind the rear drive axle. A pusher axle (Figure 34, Item 2) is mounted in front of the rear drive axle. They are considered auxiliary

axles. The pusher or tag axle is raised and lowered by a button located on the cab control box.

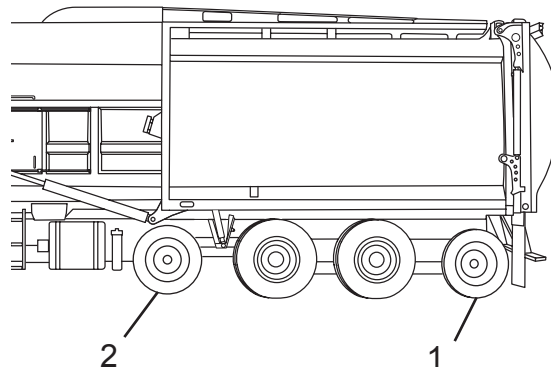

Figure 34

NOTE

Only lower the pusher or tag axle after you have started your route. Never lower the axles when the Packer is empty. When emptying the Packer the pusher axle must be in the RAISED position and the tag axle in LOWERED position.

4.2.1 Lowering the Pusher or Tag Axle

1. Bring the truck to a complete stop and apply the parking brake (refer to the chassis manufacturer's procedure).
2. Push the PUSHER AXLE or TAG AXLE LOWER button.
3. Resume normal operations.

NOTE

The tag axle is designed to lift automatically when the vehicle is put in reverse. The tag axle must be lowered again before beginning forward travel.

4.2.2 Raising the Pusher Axle or Tag Axle

1. Bring the truck to a complete stop and apply the parking brake (refer to the chassis manufacturer's procedure).
2. Press the PUSHER AXLE or TAG AXLE RAISE button.
3. Resume normal operations.

4.3 Fall Protection Equipment

4.3.1 Fall Protection Roof Anchors

Your waste collection vehicle may be equipped with anchors, loops, holes, or other features where it is possible to attach ropes, chains, hooks, or straps. These features may be

intended only for use with optional equipment not provided on your vehicle, or for use during the manufacturing process. Never use features on your waste collection vehicle to lift, tow, move, or otherwise manipulate your waste collection vehicle.

If your vehicle is equipped with anchors intended to be used for fall protection, they will be indicated as such with the following label.

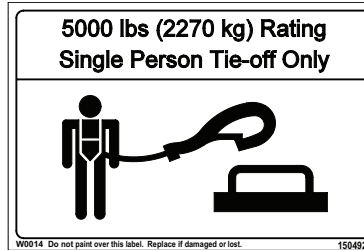

These anchors are provided either as specified by your company, or as a means of complying with ANSI Z245.1 *Mobile Wastes and Recyclable Materials Collection, Transportation, and Compaction Equipment - Safety Requirements*. Any use of these anchors must only be as part of a fall protection system designed and certified by your employer. Never use these anchors in any other way than that prescribed by your employer's safety manager.

4.3.2 Fall Protection Systems

Your Waste Collection vehicle may be equipped with a tarpARMOR™ Bi-LINE™ fall protection system. This system must be used only with the belts, clips, harnesses, tethers, and other necessary accessories as approved by tarpARMOR™ and your employer's safety manager. Do not attempt to use this system unless you are trained, experienced, properly equipped, and authorized to do so. Understand and follow the limitations of the system as explained by your tarpARMOR™ supplied instructions and your safety manager's training.

4.3.3 Working on the Roof

If your employer's safety procedures direct you to work on the roof of your waste collection vehicle without a fall protection system, only do so while maintaining three points of contact at all times. Never step, stand, or walk on a surface that is not provided with a slip resistant feature.

 **WARNING**

Fall Hazard - Railings NOT provided. Never step, stand, or walk on a surface that is not provided with a slip resistant feature. Use fall protection devices any time three points of contact cannot be maintained. Fall could injure or kill.

4.4 Water Tank

4.4.1 Water Tank Safety

WARNING

IMPORTANT ALUMINUM AND STEEL WATER TANK INFORMATION.

1. Inspect water tank on a daily basis for any damage including, but not limited to, dents, gouges in metal, or leaks.
2. Do not weld on or repair water tank. Instead, replace water tank with a new OEM water tank.
3. Never pressure test an empty water tank. Only pressure test a full water tank.
4. Never remove pressure regulator or pressure safety valve from tank.
 - If regulator or safety valve is defective, it must be replaced before Packer is put into service.
5. Do not pressurize water tank beyond its working pressure.
 - If pressure exceeds the working pressure, immediately depressurize water tank and replace pressure regulator and pressure safety valve.

WARNING

CONTINUED

6. Never drive the truck with the water tank pressurized.
 - Depressurize water tank prior to transit to or from job site.
 - Water tank should be pressurized only when being used.
7. Never modify water tank in any way.
8. Immediately replace safety decals with McNeilus decals if decals are missing or difficult to read.
9. Refer to the McNeilus Operator's Manual or contact McNeilus at 1-888-686-7278 if you have questions or require assistance.

4.4.2 Introduction

Your vehicle may be equipped with a pressurized water tank. This tank is used to rinse debris off the vehicle. Air pressure from the truck's brake system is used to provide pressure to the tank. Use these instructions for the safe operation and inspection of all McNeilus, Oshkosh, and London pressurized water tanks.

If your vehicle is equipped with a non-pressurized water tank (a system that uses a water pump to provide pressure), refer to the instructions provided with the refuse vehicle.

4.4.3 Daily Inspection

- Inspect tank daily for damage or leaks.
- Replace (do not repair) damaged or leaking tank.
- Drain pressure before driving.
- Do not weld or repair tank.
- Never exceed stated psi in tank.
- Bursting tank may injure or kill.

4.4.3.1 Tank Integrity

At the start of each shift:

- **Inspect Interior:** Drain the tank of water and use a flashlight to look into the tank through the fill opening. Look for signs of corrosion on the inside of the tank which may indicate that the tank has been weakened and is in need of replacement.
- **Inspect Exterior without Pressure:** If the interior inspection indicates that the tank is in good condition, fill the tank with water and inspect the exterior of the tank thoroughly for signs of leaks. Inspect the filler neck and fill opening. Look for signs of damage. Look for cracks in the weld joints or seams. Check that all fastening hardware is tight and undamaged. Inspect fittings for signs of damage, cracks, or looseness.

- **Inspect Exterior with Pressure:** If there are no signs or exterior leakage, pressurize the tank and repeat the inspection.
- **Depressurize Tank:** Release the pressure in the tank as soon as you are finished inspecting and before moving the truck.

Replace Defective Tank: Water tanks with any leak or significant signs of internal or external damage or corrosion should be replaced. DO NOT ATTEMPT TO REPAIR.

4.4.3.2 Pressure Regulator Valve

Inspect Pressure Regulator: The pressure regulator is used to reduce the air brake system pressure to a pressure that is safe to be in the water tank. It must be undamaged and in proper working order. Look and listen for signs of leaking. Ensure that the valve and associated hoses and fittings are undamaged.

Adjust Pressure to Correct Setting: Many pressure regulators are set at the factory and cannot be adjusted. If your water tank has an adjustable regulator, set it to 50 psi. When setting the regulator, always begin by turning the adjusting knob counterclockwise first to reduce the pressure slightly. Then turn it clockwise slowly to bring the pressure up to the correct setting. Never continue to turn the valve past the correct setting.

Replace Defective Regulator Valve: Any water tank with a damaged or missing pressure regulator valve must be removed from service immediately. Do not pressurize the tank until a functioning pressure regulator valve has been installed.

4.4.3.3 Pressure Relief Valve

Inspect the Relief Valve: The pressure relief valve is a safety device that will release air or water from the tank if it is inadvertently pressurized over the relief setting. The relief setting on most water tanks is set at the factory and cannot be adjusted. Identify the pressure relief valve and ensure that it has not been damaged or tampered with.

Replace Defective Relief Valve: Any water tank with a damaged or missing pressure relief valve must be removed from service immediately. Do not pressurize the tank until a functioning pressure relief valve has been installed.

4.4.4 Daily Operation

The water tank is designed to be used during stationary operation at the yard or the landfill site only. It is not necessary or beneficial for the tank to be pressurized while driving, and a pressurized tank is an added hazard in the event of a crash or a rollover.

4.4.5 Vehicle Handling Characteristics

Safe operation of any vehicle is the responsibility of the driver. The water tank is a fluid load that can increase the rollover tendency if the truck is driven with the water tank partially full. To reduce the risk of rollover, only drive the truck with the water tank either completely full or completely empty. Avoid making sharp turns at excessive speeds and other abrupt maneuvers.

In the event of a rollover or crash, an unbelted person is significantly more likely to become injured or die than a person wearing a seat belt. ALWAYS WEAR YOUR SEAT BELT.

4.4.6 Water Tank Decal Identification

No.	Part Number	Qty.	Comments
A	1449162	1	Use if equipped with 55 psi tank.
A	1449165	1	Use if equipped with 95 psi tank.
A	1503949	1	Use if equipped with 120 psi tank.
B	1449164	1	

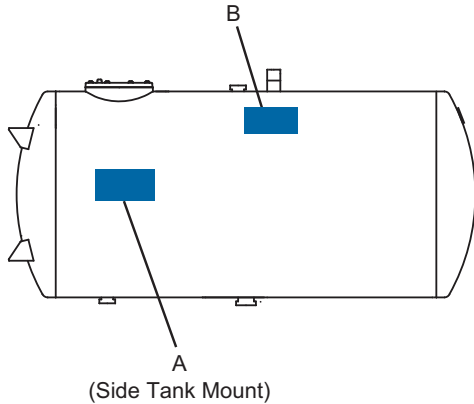

4.4.7 Water Tank Operation

The water tank (Figure 35, Item 1) can be mounted in any one of several locations, depending on the options your refuse vehicle is equipped with. The system will be equipped with a pressure gauge (Figure 35, Item 2), an air pressure control valve (Figure 35, Item 3), and a drain valve (Figure 35, Item 4).

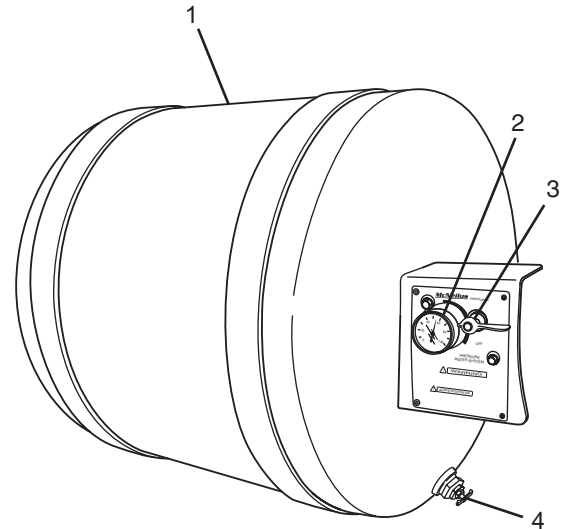
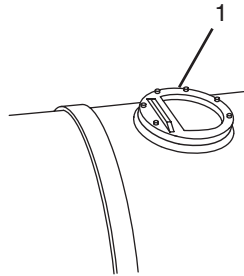

Figure 35

4.4.7.1 Filling the Tank

The tank can be filled through the flopper valve (Figure 36, Item 1) or through the optional gate valve (Figure 36, Item 2).



OR

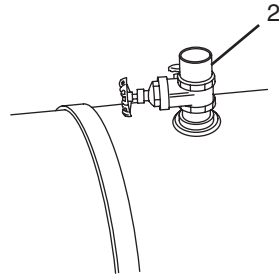

Figure 36

4.4.7.2 Pressurizing the Water Tank

WARNING

Never drive the truck with the water tank pressurized.

Serious personal injury or death may occur.

WARNING

Never pressurize an empty water tank.

Serious personal injury or death may occur.

1. Fill the tank to the desired level.

WARNING

Pressure in the water tank should never exceed 55 psi. If pressure exceeds 55 psi, depressurize tank immediately and replace with new McNeilus air regulator valve.

NEVER pressurize an empty tank.

NEVER modify tank in any way.

Operating in excess of 55 psi, pressurizing an empty tank, or modifying the tank may cause serious personal injury or death.

2. Turn the air pressure control valve to the PRESSURIZE position (Figure 37, Item 1). The water tank will be pressurized from the chassis air system.
3. The air gauge (Figure 37, Item 2) will read the pressure in the water tank. The pressure must not exceed 55 psi.

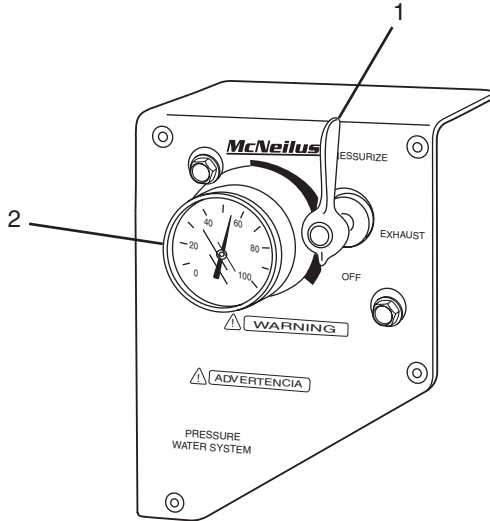

Figure 37

4. Connect a hose to the fitting (Figure 38, Item 1).

⚠ WARNING

Do not drink the water.

Serious internal injury may result.

5. Open the valve (Figure 38, Item 2).

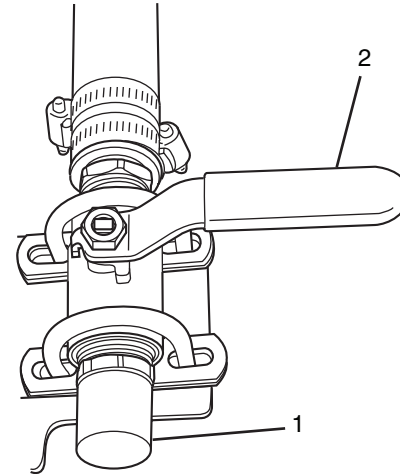

Figure 38

4.4.7.3 Depressurizing the Water Tank

1. Turn air pressure control valve to the EXHAUST position (Figure 39, Item 1). Make sure the gauges (Figure 39, Item 2) read 0 psi.

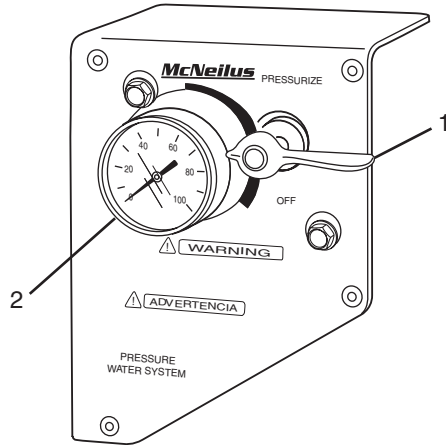

Figure 39

2. After pressure in the water tank has been completely exhausted, turn the air pressure control valve to the OFF position (Figure 40, Item 1).

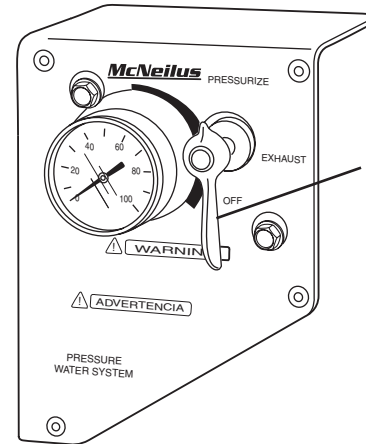

Figure 40

4.4.7.4 Draining the Water Tank

⚠ WARNING

Never allow the water from the tank to drain onto a public sidewalk or roadway. Water may cause the sidewalk or roadway to become slippery. Always drain the water system at a location designated by the job site manager or in compliance with your company policy.

Failure to comply may result in serious personal injury or death.

⚠ WARNING

Do not drink the water.
Serious internal injury may result.

⚠ CAUTION

Be sure to drain the water tank, hoses, and pipes when operating in temperatures below freezing.

Failure to drain the system may cause damage to equipment.

When operating in temperatures below freezing, the water system must be drained after every use.

1. Depressurize the water tank.
2. Open the tank drain valve (Figure 41, Item 1) and allow the water to drain. When water is drained, close the drain valve.

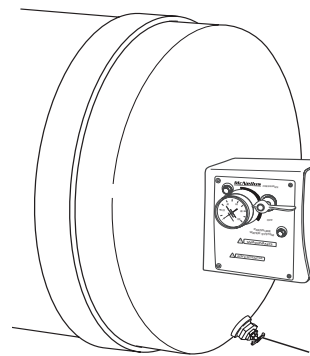

Figure 41

3. Open ball valve(s) (Figure 42, Item 1) and drain all hose(s) and pipe(s). Operate hose to drain hose and pipes.

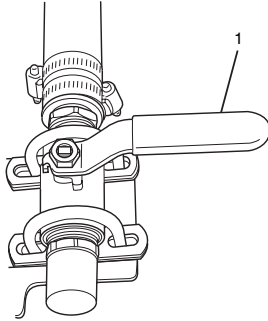

Figure 42

1.0 Preventive Maintenance

The unit must be checked or inspected each day or before each new shift of operation. Report any deficiencies to your Maintenance Department for correction by skilled service personnel.



⚠ CAUTION

Correct all identified deficiencies BEFORE operating the Packer. Failure to correct deficiencies may cause damage to equipment.

1.1 DOT Pre-Trip

Perform pre-trip inspection of chassis and refuse vehicle according to all federal, state, and local laws.

2.0 Preventive Maintenance Intervals

Performing preventive maintenance on your refuse vehicle will prolong the life of its equipment, help prevent expensive downtime, and minimize the potential for problems arising on the route.

The following Preventive Maintenance Chart summarizes the requirements to properly maintain your refuse vehicle.

The chart specifies the recommended interval when each item should be performed.

Intervals are listed in calendar and hours-of-use increments. Maintenance should be performed at the increment that occurs first.

The preventive maintenance intervals listed under the **Service** group heading are the maximum days or hours allowed for each maintenance procedure. Continue to repeat the maintenance procedures at the listed intervals.



NOTE

If the Packer is operated more hours per day or double-shifted, the maintenance interval must be adjusted accordingly.

The Preventive Maintenance Chart identifies the responsibilities to be performed by both the operator and service personnel.

Some maintenance procedures are listed under both the **Operator** group heading and **Service** group heading.

The Daily Checks under the **Operator** group heading identify procedures that can be performed by either the operator or skilled service personnel.

All intervals listed under the **Service** group heading must be performed by skilled service personnel. Refer to the product Service Manual for maintenance procedures.

Maintenance procedures are listed under the system of the refuse vehicle that is affected. Refer to the product Service Manual for maintenance procedures.

Perform your company's Lockout/Tagout procedure. If your company does not have a Lockout/Tagout procedure, follow OSHA 1910.147 and 1910.146 Confined Space as appropriate.

LEGEND

R Replace

I Inspect

T Torque

P Perform

L Lubricate

C Clean

Operator				Service			
Daily Checks	Daily (10 Hours)	Weekly (50 Hours)	Scheduled PM (150 Hours)	Semi-Annual (1250 Hours)	Annually (2500 Hours)	Bi-Annual (5000 Hours)	

Hydraulic System							
Check Hydraulic Oil Level	I			I			
Hydraulic System and Components	I			I			
Hydraulic Hoses	I			I			
Hydraulic Tubes and Fittings	I			I			
Breather Filter				I	R		
Return Line Filter					R		
Hydraulic Oil Test					P		
HOC Operation Test					P		
Test Main Relief Valve Setting					P		
Change Hydraulic Oil					P		
Change Hydraulic Oil - OPTIONAL Clean Fill System						P	
Reservoir Drain Plug					I		
Reservoir Drain Plug - OPTIONAL Clean Fill System						I	

LEGEND

- R Replace P Perform
- I Inspect L Lubricate
- T Torque C Clean

		Operator			Service			
		Daily Checks	Daily (10 Hours)	Weekly (50 Hours)	Scheduled PM (150 Hours)	Semi-Annual (1250 Hours)	Annually (2500 Hours)	Bi-Annual (5000 Hours)

Suction Line Strainer					R			
Suction Line Strainer - OPTIONAL Clean Fill System						R		
High Pressure Filter (If Applicable)					R			
Electrical System								
Lighting System	I			I				
Wire Harness	I			I				
Audible Back-Up Alarm	I							
Pneumatic System								
Drain and Inspect Coalescing Filter	I/P			I/P				
Coalescing Filter				R				
Air Hoses and Fittings	I			I				
Mechanical								
Refuse Vehicle Body and Components	I			I				
Tailgate Seal Condition	I			I				
Tailgate Lock Clearance				I				

LEGEND

R Replace

I Inspect

T Torque

P Perform

L Lubricate

C Clean

		Operator			Service			
		Daily Checks	Daily (10 Hours)	Weekly (50 Hours)	Scheduled PM (150 Hours)	Semi-Annual (1250 Hours)	Annually (2500 Hours)	Bi-Annual (5000 Hours)

Proper Operation of Tailgate/Body Cylinder Props				I				
Top Door				I				
Pack/Eject Assembly				I				
Pack/Eject Track Clearance				I				
Arm Assembly				I				
Arm Torque Tube Bolts					I/T			
Fork Assembly				I				
Pusher Axle Lug Nuts			T					
Tag Axle Lug Nuts			T					
Body Tie-Down Components (used during propping of the body) • Missing nuts or pins • Broken or damaged springs or brackets	I							

LEGEND

- R** Replace **P** Perform
- I** Inspect **L** Lubricate
- T** Torque **C** Clean

		Operator			Service			
		Daily Checks	Daily (10 Hours)	Weekly (50 Hours)	Scheduled PM (150 Hours)	Semi-Annual (1250 Hours)	Annually (2500 Hours)	Bi-Annual (5000 Hours)

Operation							
Ladders and/or Associated Equipment	I			I			
Hinges and Latching Mechanisms				I			
Pump Driveshaft Couplers				I			
Proper Operation of Proximity Switches	P			P			
Refuse Vehicle Controls	I			I			
Remove Trash Behind Pack/Eject	P			P			
Safety Signs	I						
Lubrication							
Daily	L	L					
Scheduled PM				L			

3.0 Daily Preventive Maintenance Checks

3.1 Hydraulic System

SAFETY NOTICE

Perform your company's Lockout/Tagout procedure. If your company does not have a Lockout/Tagout procedure, follow OSHA 1910.147 and 1910.146 Confined Space as appropriate.

3.1.1 Hydraulic Oil Level

- **Daily Checks** - The oil level is checked by the operator or skilled service personnel.

NOTE

Check hydraulic oil level during start-up when the oil temperature is still cold.

- Check the hydraulic oil level with all hydraulic cylinders in their fully RETRACTED position.

3.1.1.1 Temperature / Level Sight Gauge

The gauge contains a thermometer which indicates the temperature of the hydraulic oil in the reservoir. The reservoir could have one of two gauges. The first type (Figure 43) is distinguished by the word "LOW" below the sight glass. The second type (Figure 44) does not have the word "LOW" on the gauge.

The hydraulic oil must be checked with all the hydraulic cylinders in the fully RETRACTED position.

On a reservoir with a temperature/level sight gauge option (Figure 43), oil level at 60 - 70°F should be at the black line in the center of the green zone (Item 1). Oil should not be above the "Max Fill Hot" line (Figure 43, Item 2) when the system is at operating temperature. If there is too much oil in the reservoir (above the "Max Fill Hot" line), there is a possibility of the oil coming out of the breather at the top of the hydraulic reservoir. Do not operate the system with oil below the "low" line (Figure 43, Item 3) or damage to the system may result.

CAUTION

Do not operate the hydraulic system with oil below the "low" line on the temperature/level sight gauge.

Damage to the system may result.

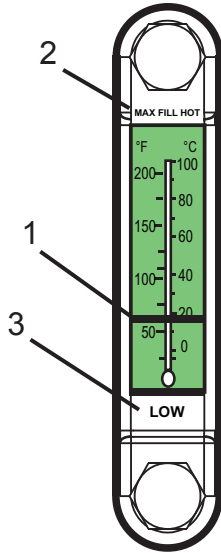

Figure 43

The second type of temperature/level sight gauge (Figure 44, Item 1) will not have the word “LOW”. Keep the oil level to the top of the black line (Full) (Figure 44, Item 2), but don't over fill. If the oil level gets to the red line (Figure 44, Item 3), oil must be added.

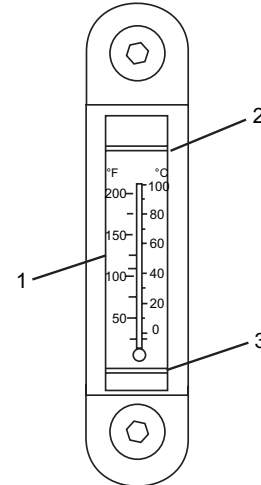

Figure 44

3.2 Electrical System

SAFETY NOTICE

Perform your company's Lockout/Tagout procedure. If your company does not have a Lockout/Tagout procedure, follow OSHA 1910.147 and 1910.146 Confined Space as appropriate.

3.2.1 Lighting System

- **Daily Checks** - The lighting system is inspected by the operator or skilled service personnel.

Check to ensure that all exterior lights on the refuse vehicle and chassis are functioning correctly. Replace any burned-out bulbs with the same type.

3.3 Pneumatic System

Perform your company's Lockout/Tagout procedure. If your company does not have a Lockout/Tagout procedure, follow OSHA 1910.147 and 1910.146 Confined Space as appropriate.

3.3.1 Coalescing Filter

- **Daily Checks** - The coalescing filter is drained by the operator or skilled service personnel.

Locate the drain fitting (Figure 45, Item 1) on the bottom of the coalescing filter.

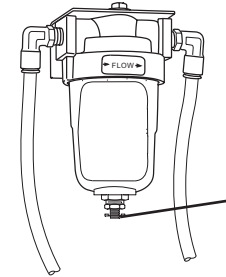

Figure 45

Drain the filter by turning the drain fitting counterclockwise. Turn the drain fitting clockwise after all moisture and contaminants have drained from the canister.

3.4 Mechanical System

SAFETY NOTICE

Perform your company's Lockout/Tagout procedure. If your company does not have a Lockout/Tagout procedure, follow OSHA 1910.147 and 1910.146 Confined Space as appropriate.

3.4.1 Refuse Vehicle Body and Components

- **Daily Checks** - The refuse vehicle body and components are inspected by the operator or skilled service personnel.

Inspect the body and all components for binding, damage, loose or missing parts.

3.4.2 Tailgate Seal

- **Daily Checks** - The tailgate seal is inspected by the operator or skilled service personnel.

Inspect the tailgate seal for tears, damage, or excessive wear. Ensure that the seal is fully seated in the tailgate channel.

Inspect the mounting straps to ensure they are secure.

3.5 Operation

WARNING

Be sure all non-operator personnel are at least 20 feet (6 meters) away from all areas of the Packer.
Serious personal injury or death may occur.

DANGER

Make sure the area above the vehicle is clear of objects and power lines before raising the arm.
Serious personal injury or death may occur.

3.5.1 Refuse Vehicle Controls

- **Daily Checks** - The refuse vehicle controls are checked for proper operation by the operator or skilled service personnel.

Operate all functions to validate they are operational. Verify that all indicator lights and alarms are operational.

3.6 Trash Behind the Pack/Eject

- **Daily Checks** - The refuse vehicle is inspected for trash behind the pack/eject by the operator or skilled service personnel.

When the refuse vehicle is operated on the route, trash can pass-by the pack/eject. If the trash is not cleaned from behind the pack/eject, the refuse vehicle can be damaged.

NOTE

Packer body must be empty when performing this procedure.

1. Raise the fork assembly fully.
2. Raise the arm to the home position.
3. While pressing the ARM OVERBODY OVERRIDE switch, extend the pack/eject.
4. Perform your company's Lockout/Tagout procedure. If your company does not have a Lockout/Tagout procedure, follow OSHA 1910.147 and 1910.146 Confined Space as appropriate.
5. Unlatch the side door handle (Figure 46, Item 1) and open the side door.
6. Inspect behind the pack/eject for accumulation of trash.
7. Remove the trash from behind the pack/eject using a clean out tool or a plastic shovel.

CAUTION

Do not damage the pack and sweep cylinder rods when cleaning out trash.

Never use metal objects or tools to clean out trash from around the pack and sweep cylinders.

Failure to comply may cause damage to equipment.

8. After the trash is removed, close and secure the side door and fold up the ladder.
9. Remove Lockout/Tagout.
10. Retract the Pack/Eject.

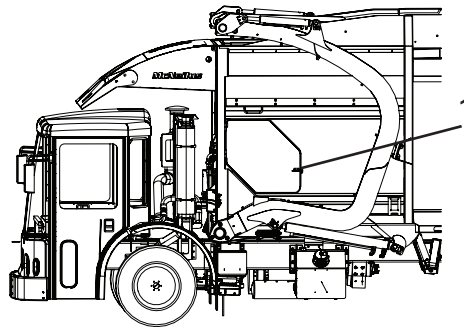

Figure 46

3.7 Safety Signs

- **Daily Checks** - A complete walk around of the vehicle to inspect the safety signs should be performed every day before operation. If any of the safety signs are damaged, illegible, or missing, they must be replaced before operation.

For the proper location and part numbers of the safety signs for the refuse vehicle, see SAFETY SIGNS. If you are unable to determine the proper safety sign or its placement on the refuse vehicle, call McNeilus Truck and Manufacturing, Inc. at 888-686-7278 for assistance. Call 888-686-7278 or visit www.streetsmartparts.com to order replacement safety signs. Use only McNeilus replacement safety signs.

For information on any of the chassis safety signs, please contact the chassis manufacturer.

4.0 Propping the Tailgate

When performing maintenance procedures that require the tailgate to be open, the following procedure for your type of tailgate prop must be followed to open and prop the tailgate.

DANGER

Whenever the tailgate is in a raised position, it must be securely propped or blocked so it cannot fall on anyone.

Serious personal injury or death may occur.

WARNING

Be sure all non-operator personnel are at least 20 feet (6 meters) away from all areas of the Packer.

Serious personal injury or death may occur.

DANGER

Make sure the area above the vehicle is clear of objects and power lines before raising the body or buckets, or opening the tailgate.

Serious personal injury or death may occur.

⚠ DANGER

Stand clear when the tailgate is in motion and during the unloading cycle. Do not stand under or cross under the raised tailgate. Serious personal injury or death may occur.

Condition

- Arms and forks must be in the HOME position

4.7.1 Engaging the Standard Tailgate Prop

1. Standing behind the tailgate, release the pin (Figure 47, Item 1) and swing the prop (Figure 47, Item 2) toward the truck frame.
2. Start the engine and raise the tailgate.

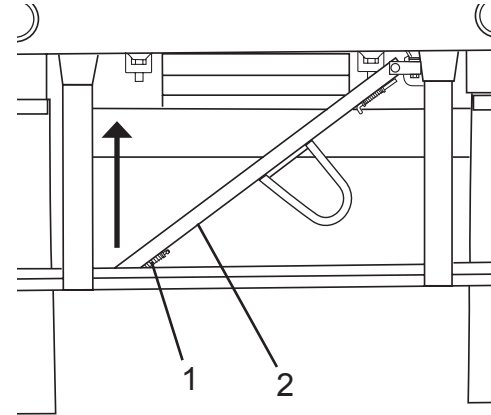

Figure 47

3. Disable the refuse vehicle and shut the chassis engine off.
4. Perform your company's Lockout/Tagout procedure. If your company does not have a Lockout/Tagout procedure, follow OSHA 1910.147 and 1910.146 Confined Space as appropriate.

5. Position the end of the prop (Figure 48, Item 1) over the pocket (Figure 48, Item 2).

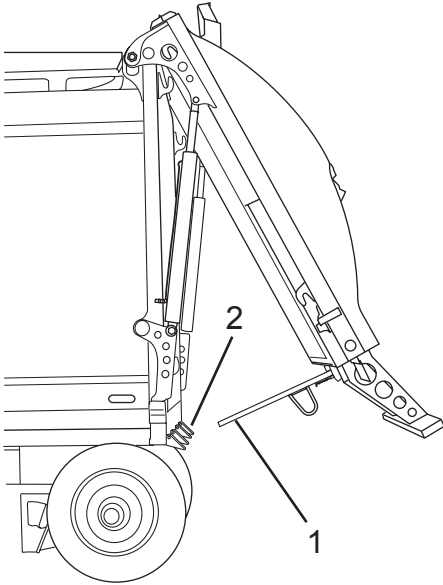

Figure 48

CAUTION

Do not **POWER DOWN** the tailgate against the props.
Damage may occur to the props.

6. Turn ignition switch to the ON position. Do not start engine. Lower the tailgate until the prop (Figure 49, Item 1) are fully seated in the pocket (Figure 49, Item 2).

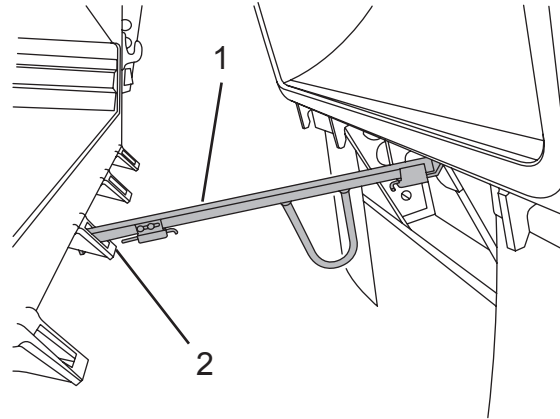

Figure 49

DANGER

Verify that the tailgate props are properly seated in the pockets off the body compartment.

Serious personal injury or death may occur.

7. Turn ignition switch to the OFF position.
8. Always use a stick, shovel, or long handled brush to clear trash from the props and seal areas of tailgates and doors.

4.7.2 Disengaging the Standard Tailgate Prop

After completing the maintenance procedures on the body that require the tailgate to be propped, the following procedure must be followed to disengage the prop and close the tailgate.

1. Remove your company's Lockout/Tagout per your company's procedure from the refuse vehicle. If your company does not have a Lockout/Tagout procedure, follow OSHA 1910.147 and 1910.146 Confined Space as appropriate.
2. Start the engine and open the tailgate as needed to provide the necessary clearance to disengage the prop from the pocket in the body compartment.
3. Shut the engine OFF and put the key in your pocket.

4. Standing behind the tailgate remove the prop from the pocket and swing the prop (Figure 50, Item, 1) away to the stored position and install retaining pin (Figure 50, Item 2).

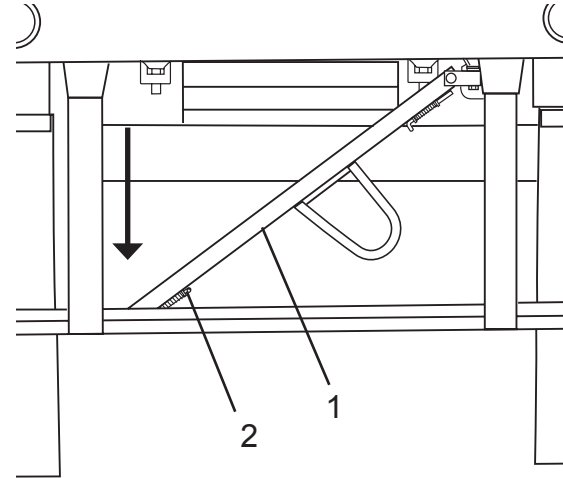

Figure 50

5. Start the chassis engine and close the tailgate.

4.7.3 Engaging the Hinge Design Tailgate Prop

CAUTION

There is a tailgate prop on each side of the body. This propping procedure must be performed on both sides of the body. Damage or injury may occur if both props are not used.

1. Remove the pin (Figure 51, Item 1) securing the props to the body.
2. Slide the props (Figure 51, Item 2) out away from the body.

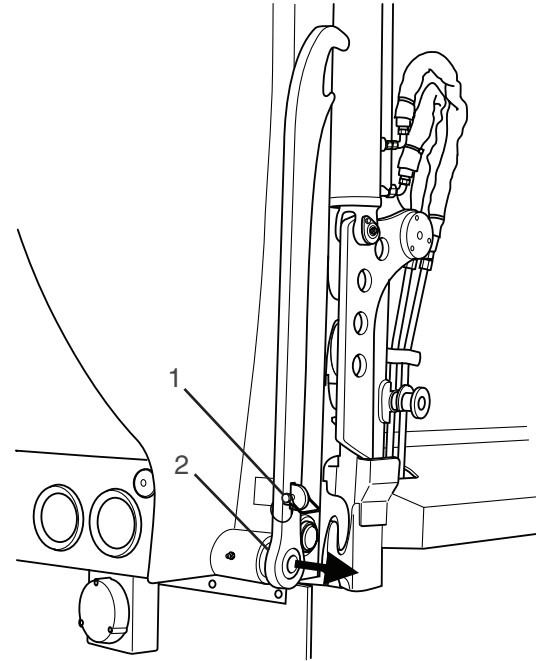

Figure 51

3. Rotate the props (Figure 52, Item 1) forward and rest it on the pin (Figure 52, Item 2) on the body.

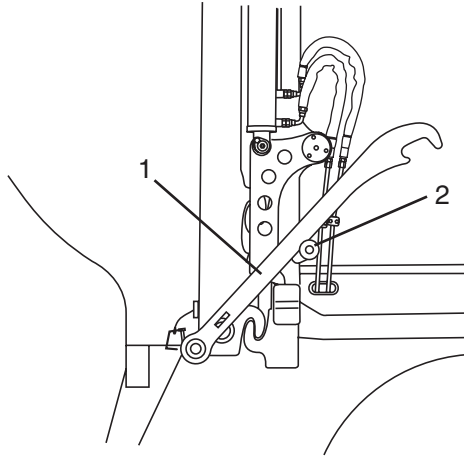

Figure 52

4. Start the chassis engine and slowly begin raising the tailgate.
5. Continue raising the tailgate until the props drop over the pin on the body.
6. Disable the refuse vehicle and shut the chassis engine off.
7. Perform your company's Lockout/Tagout procedure. If your company does not have a Lockout/Tagout

procedure, follow OSHA 1910.147 and 1910.146 Confined Space as appropriate.

⚠ CAUTION

**Do not POWER DOWN the tailgate against the props.
Damage may occur to the props.**

8. Turn ignition switch to the ON position. Do not start engine. Lower the tailgate until the props (Figure 53, Item 1) are fully seated against the pin (Figure 53, Item 2) on the body.

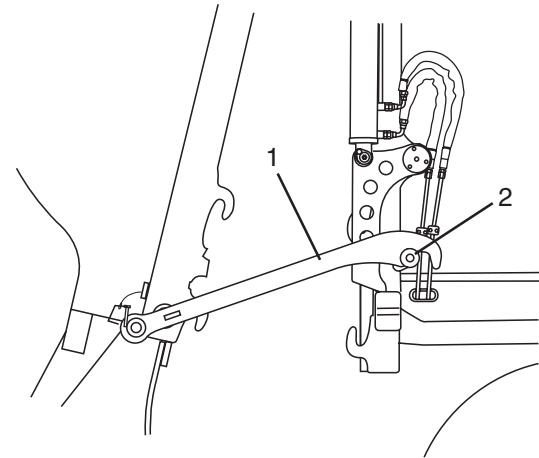

Figure 53

DANGER

Verify that the tailgate prop is fully seated against the pin.

Serious personal injury or death may occur.

9. Turn ignition switch to the OFF position.
10. Always use a stick, shovel, or long handled brush to clear trash from the props and seal areas of tailgates and doors.

4.7.4 Disengaging the Hinge Design Tailgate Prop

After completing the maintenance procedures on the body that require the tailgate to be propped, the procedure below must be followed to remove the props and close the tailgate.

1. Remove your company's Lockout/Tagout per your company's procedure from the refuse vehicle. If your company does not have a Lockout/Tagout procedure, follow OSHA 1910.147 and 1910.146 Confined Space as appropriate.
2. Start the engine and open the tailgate as needed to provide the necessary clearance to lift the props off of the pin on the body.
3. Shut the engine off and put the key in your pocket.
4. Standing to the side of the tailgate, lift the props off of the pin and rotate the props to the rear of the body.

5. Push the props (Figure 54, Item 2) toward the body, over the metal tab.
6. Install the pin (Figure 54, Item 1) through the metal tab to secure the props.

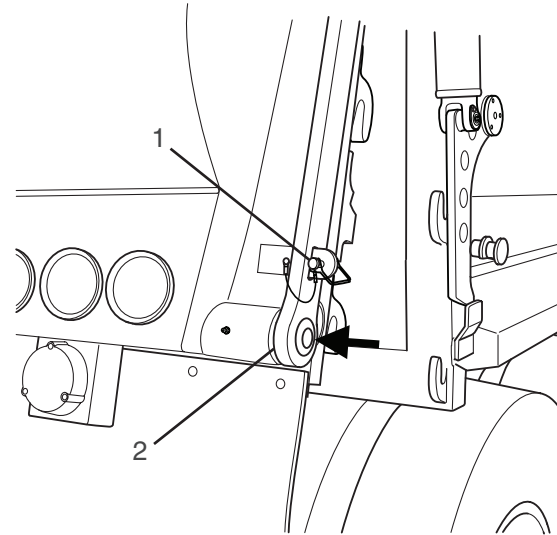

Figure 54

7. Start the chassis engine and close the tailgate.

5.0 Canopy Lift/Lower

5.1 Procedure for the Manual Canopy Lift Design

Use two people to conduct the steps at the same time.

Perform your company's Lockout/Tagout procedure. If your company does not have a Lockout/Tagout procedure, follow OSHA 1910.147 and 1910.146 Confined Space as appropriate.

NOTE: The canopy may have only one wing nut located on the street side instead of two.

Lifting the Canopy

1. Place unit on a flat surface, block truck tires.
2. Raise the arms into the hopper.
3. Place a ladder on either side of the truck, one next to the street side cab door and one next to the curb side cab door in order to reach under the canopy.
4. Locate the wing nuts under the canopy lock the canopy in current position (Figure 55).

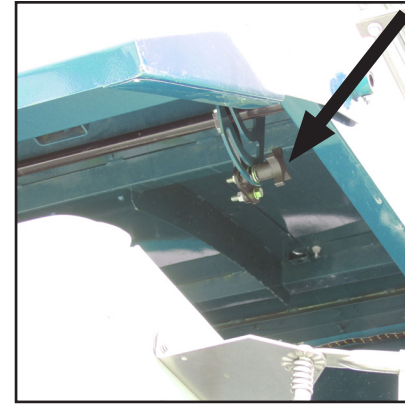

Figure 55

5. Rotate the wing nuts just until loosened (Figure 56).



Figure 56

6. Push up on the canopy until it can no longer go up. Hold it in place during the next step (Figure 57).
7. Rotate the wing nuts until they are tightened.



Figure 57

8. The canopy is now held in the UP position.
9. The cab can now be tilted up.

Lowering the Canopy

1. Lower the cab.
2. Place the ladders, one next to the street side cab door and one next to the curb side cab door in order to reach under the canopy.
3. Locate the wing nuts to rotate the canopy (Figure 55).
4. Rotate the wing nuts until they can no longer be loosened.
5. Lower the canopy all the way down.

6. Rotate the wing nuts until they are tightened.
7. Procedure is complete. Return truck to service.

5.2 Procedure for the Pneumatic Canopy Lift Design

Lifting the Canopy

The truck uses a pneumatic cylinder to lift and lower the canopy (see Figure 58 for location of the pneumatic cylinder under the canopy).

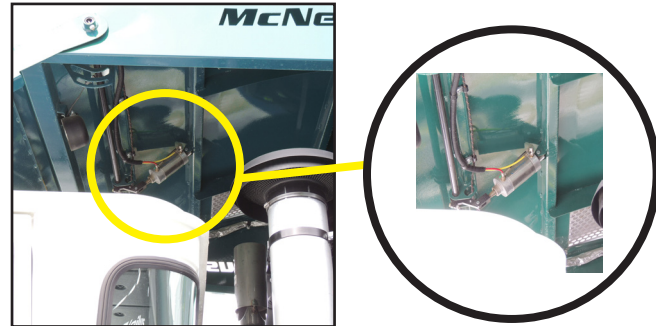

Figure 58

1. Place unit on a flat surface, block truck tires.
2. Make sure the truck has enough air.
3. Raise the arms into the hopper.

4. Locate the pneumatic canopy control button which will be outside between the cab and the body (Figure 59).



Figure 59

5. Push up on the transit latch that holds the canopy control button in position to unlatch the button.
6. Push the control button to lift the canopy.
7. The canopy is now held in the UP position.
8. Push the transit latch down on the control button to keep it in that position.
9. The cab can now be tilted up.

Lowering the Canopy

1. Lower the cab.
2. Push up on the transit latch that holds the canopy control button in position to unlatch the button.
3. Pull the control button to lower the canopy all the way down.
4. Push the transit latch down on the control button to keep it in that position.
5. Procedure is complete. Return truck to service.

6.0 Lubrication

6.1 Daily Lubrication

Lubricate all the following points with a high quality EP No. 2 lithium grease.

Daily lubrication intervals are based on a 10-hour day. If refuse vehicle is operated more hours per day or double shifted, the maintenance interval must be adjusted accordingly.

SAFETY NOTICE

Perform your company's Lockout/Tagout procedure. If your company does not have a Lockout/Tagout procedure, follow OSHA 1910.147 and 1910.146 Confined Space as appropriate.

Daily Lubrication Points		Lubricate Daily or Every 10 Hours	
Ref.	Description	No. of Fittings	Comments
A1	Pack/Eject Cylinders - Base End	2	Two Cylinders - One Per Side
A2	Pack/Eject Cylinders - Rod End	2	Two Cylinders - One Per Side
B	Arm Cylinders - Base End	2	Two Cylinders - One Per Side
B	Arm Cylinders - Rod End	2	Two Cylinders - One Per Side
C1	Arm Pillow Blocks	2	Street Side and Center
C2	Arm Pillow Blocks	1	Curb Side
D1	Fork Cylinders - Base End	2	Two Cylinders - One Per Side
D2	Fork Cylinders - Rod End	2	Two Cylinders - One Per Side
E	Fork Assembly Pivot	4	Two Pivots - Two Fittings Per Side

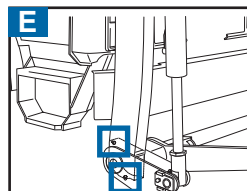
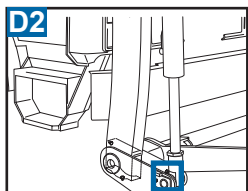
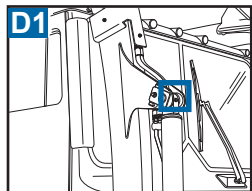
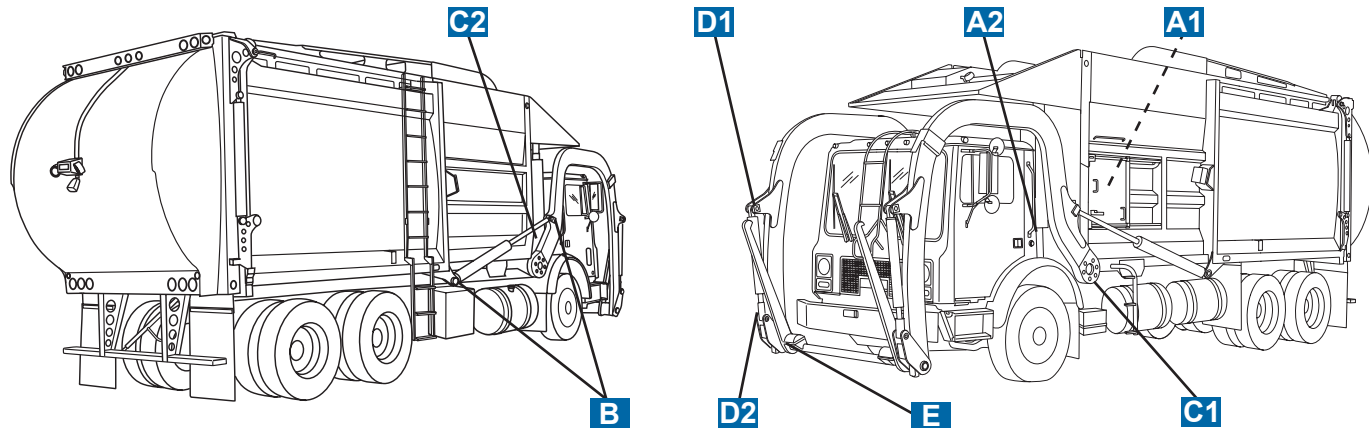
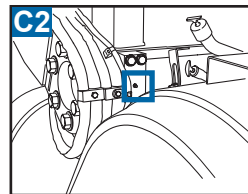
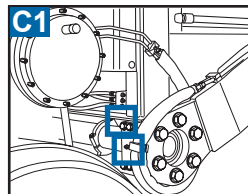
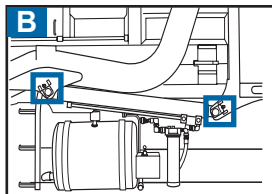
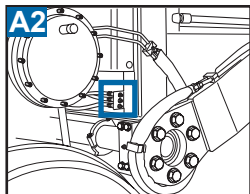
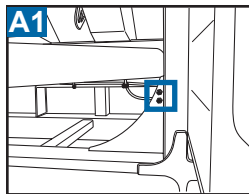

6.2 Scheduled PM Lubrication

Lubricate all the following points with a high quality EP No. 2 lithium grease.

Scheduled PM lubrication intervals are based on 3 weeks or 150 hours. If the refuse vehicle is operated more hours or double shifted, the maintenance interval must be adjusted accordingly.

SAFETY NOTICE

Perform your company's Lockout/Tagout procedure. If your company does not have a Lockout/Tagout procedure, follow OSHA 1910.147 and 1910.146 Confined Space as appropriate.

Lubrication Points		Lubricate Every 3 Weeks or Every 150 Hours	
Ref.	Description	No. of Fittings	Comments
F	Tailgate Cylinder - Base End	2	Two Cylinders - One Per Side
F	Tailgate Cylinder - Rod End	2	Two Cylinders - One Per Side
G	Tailgate Latch Pin	2	Two Latch Pins - One Per Side
H	Tailgate Hinge Pin	2	Two Hinge Pins - One Per Side
J1	Top Door - Base End	1	
J2	Top Door - Rod End	1	
K	Body Pivot Pin	2	Two Pivot Pins - One Per Side
L	Service Lift Cylinder - Base End (OPTIONAL)	2	Two Cylinders - One Per Side
L	Service Lift Cylinder - Rod End (OPTIONAL)	2	Two Cylinders - One Per Side
M	PTO Shaft U-Joints	3	
N	Tailgate Prop Pivot (OPTIONAL)	2	Two Pivot Pins - One Per Side

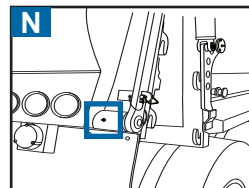
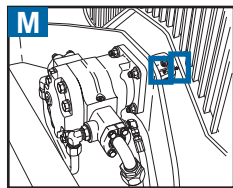
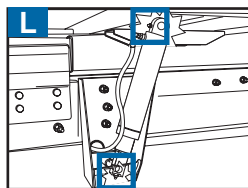
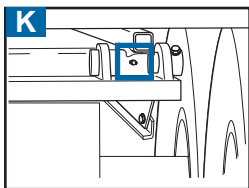
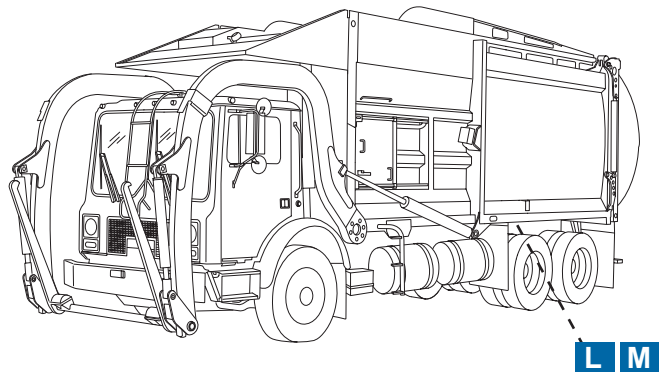
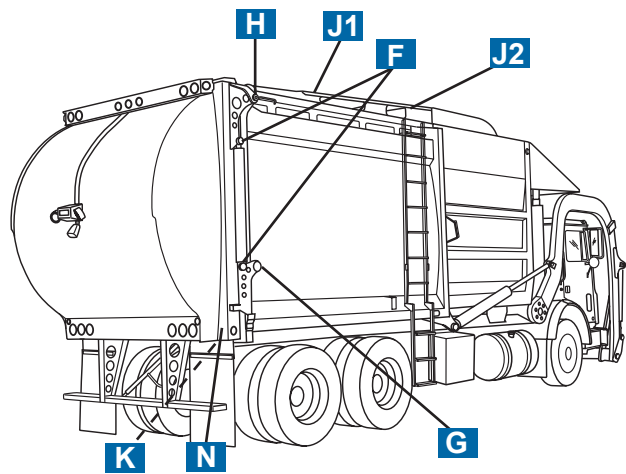
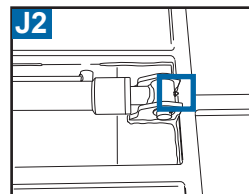
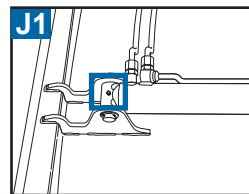
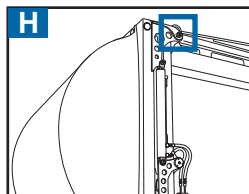
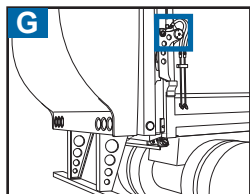
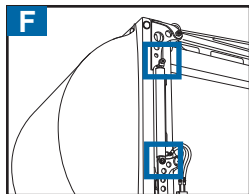

1.0 Introduction

When a problem or malfunction occurs, follow these steps. The sequence below will help isolate the problem and often permit a quick repair. If further assistance is required, refer to the applicable section of this manual or call McNeilus Parts and Service at 888-686-7278.

1.1 Onboard Diagnostics

This vehicle is equipped with onboard diagnostics to help troubleshoot a problem. The error code LEDs will light up when there is a problem.

1. To enter the diagnostic mode, press and hold both blank buttons on the in-cab controls for five seconds.
2. Depending on the type of error, 1 to 6 LED lights will be displayed on the in-cab controls above the blank buttons.
3. Use the error code decal that is located on the console inside the cab to determine what the problem is.
4. Correct the problem with the vehicle before putting it back into service.

System	Standard/Option	Error	Number	Code
Body Unloader	S	Open	9	○○●○○●
Body Unloader	S	Short	10	○○●○○●
Ejector Dump	O	Open	11	○○●○○●
Ejector Dump	O	Short	12	○○●○○●
Packer Ext	S	Open	13	○○●○○●
Packer Ext	S	Short	14	○○●○○●
Packer Ret	S	Open	15	○○●○○●
Packer Ret	S	Short	16	○○●○○●
Top Door Open	S	Open	17	○○●○○●
Top Door Open	S	Short	18	○○●○○●
Top Door Closed	S	Open	19	○○●○○●
Top Door Closed	S	Short	20	○○●○○●
Tailgate Open	S	Open	21	○○●○○●
Tailgate Open	S	Short	22	○○●○○●
Tailgate Closed	S	Open	23	○○●○○●
Tailgate Closed	S	Short	24	○○●○○●
HOC Override	O	Open	27	○○●○○●
HOC Override	O	Short	28	○○●○○●
Warm Up Coil	O	Open	29	○○●○○●
Warm Up Coil	O	Short	30	○○●○○●
Extend / Retract Prox Both On	S	Fault	31	○○●○○●
OEM CAN Signal Not Present	S	Not Online	52	●●○○○○
OEM CAN Signal Not Present	S	Not Online	53	●●○○○○
OEM CAN Signal Not Present	S	Not Online	54	●●○○○○
Cab Switch Panel - Signal	O	Not Online	55	●●○○○○
Cab Switch Panel - Signal	S	Not Online	56	●●○○○○
E-Stop Condition	S	E-Stop Condition	64	●●●●●●

1423203

NOTE

Isolate the problem before taking any remedial actions.

1. Unless further damage will occur, repeat the steps that caused the problem. Refer to the Operation section of this manual to be sure that the correct operating procedures have been followed. Often a simple step in the standard operating procedure has been forgotten.
2. Refer to the troubleshooting chart. It is designed to help you troubleshoot problems at your location, and is organized in a logical sequence. Look under the appropriate equipment section, and for the specific problem within the chart.
3. Perform the checkout procedure and remedial actions listed within the chart to isolate the problem.
4. If your particular problem is not listed, or the remedial actions provided do not resolve the problem, we suggest that you take the vehicle to a service shop, refer to the appropriate service manual, or contact McNeilus Truck and Manufacturing, Inc. for assistance.
5. If you have questions or need help, please call the McNeilus Parts and Service number listed in the Foreword of this manual.
6. Perform your company's Lockout/Tagout procedure. If your company does not have a Lockout/Tagout procedure, follow OSHA 1910.147 and 1910.146 Confined Space as appropriate.

1.2 Troubleshooting Chart

Problem	Probable Cause	Action
All functions not working	<ol style="list-style-type: none"> 1. BATTERY switch is OFF. 2. IGNITION switch is OFF. 3. One or more E-STOP buttons is DOWN. 4. PUMP switch is OFF. 5. Side door is OPEN. 6. System air pressure is too low. 7. System problem. 	<ol style="list-style-type: none"> 1. Turn BATTERY switch ON. 2. Turn IGNITION switch ON. 3. Release all E-STOP buttons. 4. Turn PUMP switch ON. 5. CLOSE side door. 6. Wait for chassis air system to build pressure above 80 psi. 7. Requires shop service and repair.
Joystick Function not working	<ol style="list-style-type: none"> 1. Engine rpm is too HIGH. 2. Pack/eject is not in HOME position. 3. Top door is not fully OPEN. 4. System air pressure is too LOW. 5. System problem. 	<ol style="list-style-type: none"> 1. REDUCE engine speed to below 1600 rpm. 2. Manually RETRACT pack/eject to HOME position. 3. Fully OPEN top door. 4. Wait for chassis air system to build pressure above 80 psi. 5. Requires shop service and repair.
Automatic Pack/Eject Functions not working	<ol style="list-style-type: none"> 1. Engine rpm is too HIGH. 2. Tailgate is OPEN. 3. Top door is not fully OPEN. 4. Arms are ABOVE the body. 5. Check pack/eject proximity switches for proper operation. 6. System problem. 	<ol style="list-style-type: none"> 1. REDUCE engine speed to below 1600 rpm. 2. CLOSE tailgate. 3. Fully OPEN top door. 4. LOWER arms below body. 5. Requires shop service and repair. 6. Requires shop service and repair.
Manual Pack/Eject Functions not working	<ol style="list-style-type: none"> 1. Engine rpm is too HIGH. 2. Top door is not fully OPEN. 3. Arms are ABOVE the body. 4. System problem. 	<ol style="list-style-type: none"> 1. REDUCE engine speed to below 1600 rpm. 2. Fully OPEN top door. 3. LOWER arms below body. 4. Requires shop service and repair.

Problem	Probable Cause	Action
Tailgate Functions not working	<ol style="list-style-type: none"> 5. Engine rpm is too HIGH. 6. ACTIVATE button not pressed. 7. System problem. 	<ol style="list-style-type: none"> 1. REDUCE engine speed to below 1600 rpm. 2. Press ACTIVATE button while pressing TAILGATE button. 3. Requires shop service and repair.
Top Door Function not working	<ol style="list-style-type: none"> 1. Engine rpm is too HIGH. 2. ACTIVATE button not pressed. 3. System problem. 	<ol style="list-style-type: none"> 1. REDUCE engine speed to below 1600 rpm. 2. Press ACTIVATE button while pressing TOP DOOR button. 3. Requires shop service and repair.

Index

A

Arm and Fork Controls	50
Arm Functions	61
Auto Dump Functions (OPTIONAL)	63

B

Battery Disconnect Switch	2
Battery Cable Disconnect	2

C

Canopy Lift/Lower	99
Procedure for the Manual Canopy Lift Design	99
Procedure for the Pneumatic Canopy Lift Design	100
Complete Vehicle Document Decal	2
Control Functions	56
Arm Functions	61
Auto Dump Functions (OPTIONAL)	63
E-STOP (Emergency Stop) Function	56
Fork Functions	62
Pack/Eject Functions	58
Tailgate Functions	64

D

Daily Checks	87
Canopy Lift/Lower	99
Procedure for the Manual Canopy Lift Design	99
Procedure for the Pneumatic Canopy Lift Design	100
Electrical System	89
Lighting System	89
Hydraulic System	87
Hydraulic Oil Level	87
Mechanical System	90
Tailgate Seal	90
Operation	90
Packer Controls	90
Pneumatic System	89
Coalescing Filter	89
Propping the Tailgate for Maintenance	92
Disengaging the Optional Tailgate Prop	98
Disengaging the Standard Tailgate Prop	95
Safety Signs	92
Trash Behind the Pack/Eject	102

E

Exterior Systems Arrangement	27
Curb Side View	28
Street Side View	27
S-Type Container Specifications	29

F

Fork Functions 62

I

Identification Plate 1

Instruments and Controls 31

 Cab Controls 40

L

Low Profile In-Cab Controls

 Arm and Fork Controls 50

 Auto Dump Single Lever 54

 Dual Lever Controls (OPTIONAL) 53

 Single Lever Joystick Control 51

 Single Lever Joystick Control (OPTIONAL) 52

 Street Side/Curb Side Switch 50

In-Cab Control Panel

 Fuse Block 48

 LED Indicator Light Functions 45

 Packer Switch Functions 42

 Outside Control Box (OPTIONAL) 55

Lubrication 102

 Daily Lubrication 102

 Scheduled PM Lubrication 105

M

Mechanical System

 Refuse Vehicle Body and Components 90

 Tailgate Seal 90

N

National Highway Traffic Safety Administration (NHTSA) 3

O

Operating Procedures

 End of Day Checks 39

 Neutral Interlock Test Procedure for Optional Neutral

 Interlock 35

 Preparation Before Starting Route 35

 Refuse Empty Procedure 38

 Refuse Loading Procedure 36

 Start-Up Procedure 31

 Traveling Procedure - Residential 34

 Traveling Procedure - Standard 33

 Warm-Up Procedure 32

Optional Equipment 67

 Fall Protection Equipment 70

 Pusher Axle or Tag Axle 67

 Residential Attachments 67

 Installing a Carry Can 68

 Water Tank 72

 Daily Inspection 73

 Daily Operation 74

Introduction72
 Vehicle Handling Characteristics74
 Water Tank Decal Identification75
 Water Tank Operation75
 Water Tank Safety72

P

Preventive Maintenance 81
 DOT Pre-Trip 81
 Preventive Maintenance Intervals 81
 Product Safety Information 5
 Cab Operation 6
 Hydraulics 18
 Maintenance 10
 Outside Operation 13
 Safety 5
 Pusher Axle 67

R

Reporting Safety Defects 3

S

Safety Equipment 3
 Fire Extinguisher 3
 Reflective Warning Triangle Kit 3
 Safety Notices 4
 Safety Alert Symbol 4

Safety Signs 22
 Safety Sign Location 24
 Service Branch 4

T

Tag Axle 69
 Troubleshooting
 Onboard Diagnostics 107
 Troubleshooting Chart 109

W

Warning Triangle Kit 3
 Water Tank 72

THIS PAGE INTENTIONALLY LEFT BLANK

THIS PAGE INTENTIONALLY LEFT BLANK

McNeilus[®]

888-686-7278

www.StreetSmartParts.com